



SHERWOOD INDUSTRIES IS AN ENVIRONMENTALLY RESPONSIBLE COMPANY. THIS MANUAL IS PRINTED ON RECYCLED PAPER.  
PLEASE KEEP THESE INSTRUCTIONS FOR FUTURE REFERENCE



# PELLET STOVE **Empress**

## Fireplace Insert

# TECHNICAL MANUAL



Contact your building or fire officials about restrictions and installation inspection requirements in your area.





**PLEASE READ THIS ENTIRE MANUAL BEFORE INSTALLATION AND USE OF THIS PELLET BURNING ROOM HEATER. FAILURE TO FOLLOW THESE INSTRUCTIONS COULD RESULT IN PROPERTY DAMAGE, BODILY INJURY, OR EVEN DEATH.**

50-1386

# TABLE OF CONTENTS

---

Introduction.....	3
Rating Label Location.....	3
Important Safety Data.....	3
Safety Warnings And Recommendations.....	3
Automatic Safety Features.....	4
Installation.....	5
Removing Pellet Stove From Pallet.....	5
Dimensions.....	5
Clearances to Combustibles.....	6
Masonry Fireplace Installation.....	7
Positive Flue Connection without a Full Reline (USA Only).....	8
Adjusting Hopper Height .....	9
Installation of Cast Skirt Option.....	9
Surround Panel Installation.....	10
Thermostat Installation.....	10
Slider/Damper Setting.....	11
Troubleshooting.....	12
Wiring Diagram.....	15
Parts List.....	16
Parts Diagram - Components.....	18
Parts Diagram - Parts.....	19
Warranty.....	20
Installation Data Sheet.....	23

 <p><b>NATIONAL FIREPLACE INSTITUTE</b> <b>NFI</b> <b>CERTIFIED</b> <a href="http://www.nficertified.org">www.nficertified.org</a></p>	<p>We recommend that our pellet hearth products be installed and serviced by professionals who are certified in the U.S. by the National Fireplace Institute® (NFI) as NFI Pellet Specialists or who are certified in Canada by Wood Energy Technical Training (WETT).</p>	 <p><b>Wood Energy Technical Training</b> <a href="http://www.wettinc.ca">www.wettinc.ca</a></p>
---	--	--

# INTRODUCTION

---

\* **This manual is designed for the technician in conjunction with the owner's manual.** \*

## **RATING LABEL LOCATION:**

---

The rating label is located on the hopper top behind the surround panel.

## **IMPORTANT SAFETY DATA:**

---

**Please read this entire Owner's Manual before installing or operating this ENVIRO Pellet Stove. Failure to follow these instructions may result in property damage, bodily injury or even death.** Contact your local building or fire official to obtain a permit and any information on installation restrictions and inspection requirements for your area.

**To prevent the possibility of a fire, ensure that the appliance is properly installed by adhering to the installation instructions.** An ENVIRO dealer will be happy to assist you in obtaining information with regards to your local building codes and installation restrictions.

Be sure to maintain the structural integrity of the home when passing a vent through walls, ceilings, or roofs.

The stove's exhaust system works with negative combustion chamber pressure and a slightly positive chimney pressure. It is very important to ensure that the exhaust system be sealed and airtight. The ash pan and viewing door must be locked securely for proper and safe operation of the pellet stove.

Do not burn with insufficient combustion air. A periodic check is recommended to ensure proper combustion air is admitted to the combustion chamber. Setting the proper combustion air is achieved by adjusting the slider damper located in the front of the unit under the ash pan.

When installing the stove in a mobile home, it must be electrically grounded to the steel chassis of the home and bolted to the floor. Make sure that the structural integrity of the home is maintained and all construction meets local building codes.

Soot or creosote may accumulate when the stove is operated under incorrect conditions such as an extremely rich burn (black tipped, lazy orange flames).

If you have any questions with regard to your stove or the above-mentioned information, please feel free to contact your local dealer for further clarification and comments.

## **SAFETY WARNINGS AND RECOMMENDATIONS:**

---

**Caution: Do not connect to any air distribution duct or system.**

**Do not burn garbage or flammable fluids such as gasoline, naphtha or engine oil. Unit hot while in operation. Keep children, clothing and furniture away. Contact may cause skin burns.**

**SOOT:** Operation of the stove with insufficient combustion air will result in the formation of soot which will collect on the glass, the heat exchanger, the exhaust vent system, and may stain the outside of the house. This is a dangerous situation and is inefficient. Frequently check your stove and adjust the slider/damper as needed to ensure proper combustion. **See: "INSTALLATION - SLIDER/DAMPER SETTING".**

**FLAMMABLE LIQUIDS:** **Never** use gasoline, gasoline-type lantern fuel, kerosene, charcoal lighter fluid, or similar liquids to start or "freshen up" a fire in the heater. Keep all such liquids well away from the heater while it is in use.

# INTRODUCTION

---

**ELECTRICAL:** The use of a surge protected power bar is recommended. The unit must be grounded. The grounded electrical cord should be connected to a standard 120 volts, 60 hertz electrical outlet and also must be accessible. If this power cord should become damaged, a replacement power cord must be purchased from the manufacturer or a qualified ENVIRO dealer. Be careful that the electrical cord is not trapped under the appliance and that it is clear of any hot surfaces or sharp edges. This unit's maximum power requirement is (4.1 Amps) 500 watts.

**GLASS:** Do not abuse the glass by striking or slamming the door. Do not attempt to operate the stove with broken glass. The stove uses ceramic glass. Replacement glass must be purchased from an ENVIRO dealer. Do not attempt to open the door and clean the glass while the unit is in operation or if glass is hot. To clean the glass, use a soft cotton cloth and mild window cleaner, gas or wood stove glass cleaner, or take a damp paper towel and dip into the fly ash. This is a very mild abrasive and will not damage the glass.

**SMOKE DETECTOR:** Smoke detectors should be installed and maintained in the structure when installing and operating a pellet burning appliance.

**OPERATION:** The ash pan and door must be closed securely for proper and safe operation of the pellet stove. Also ensure all gaskets on the door are checked and replaced when necessary.

**INSTALLATION:** Be sure to maintain the structural integrity of your home when passing a vent through walls, ceilings, or roofs. It is recommended that the unit be secured into its position in order to avoid any displacement.

DO NOT INSTALL A FLUE DAMPER IN THE EXHAUST VENTING SYSTEM OF THIS UNIT.

DO NOT CONNECT THIS UNIT TO A CHIMNEY FLUE SERVING ANOTHER APPLIANCE.

**FRESH AIR:** Outside Fresh Air is optional. Consider all large air moving devices when installing your unit and provide room air accordingly. Limited air for combustion may result in poor performance, smoking and other side effects of poor combustion.

If you have any questions with regards to your stove or the above-mentioned information, please feel free to contact your local dealer for further clarification and comments.

**SINCE SHERWOOD INDUSTRIES LTD. HAS NO CONTROL OVER THE INSTALLATION OF YOUR STOVE, SHERWOOD INDUSTRIES LTD. GRANTS NO WARRANTY IMPLIED OR STATED FOR THE INSTALLATION OR MAINTENANCE OF YOUR STOVE. THEREFORE, SHERWOOD INDUSTRIES LTD. ASSUMES NO RESPONSIBILITY FOR ANY CONSEQUENTIAL DAMAGE(S).**

## SAVE THIS INSTRUCTION MANUAL FOR FUTURE REFERENCE

### **AUTOMATIC SAFETY FEATURES:**

---

Your pellet Stove has the following safety features:

- A) The stove will shut off when the fire goes out and the exhaust temperature drops below 120 °F (49°C).
- B) The stove has a high temperature safety switch. If the temperature on the hopper reaches 200 °F (93 °C) the auger will automatically stop and you will get a #2 flash code, and the stove will shut off when the exhaust temperature cools. If this happens call your local dealer to reset the 200 °F (93 °C) high limit switch. FIND THE REASONS WHY THE UNIT OVERHEATED.
- C) The unit is equipped with a vacuum switch to monitor the venting and the build up of ash in the burn pot; if either becomes blocked the vacuum switch will turn off the auger and the stove will shut off.

# INSTALLATION

## REMOVING PELLET STOVE FROM PALLET:

Use a flathead screwdriver or  $\frac{5}{16}$ " socket to remove the four (4) screws that secure the Empress FPI to the pallet. Two (2) of the screws are shown in Figure 1 and the other two (2) are in the same location but on the opposite side; behind the circuit board and beside the power cord.

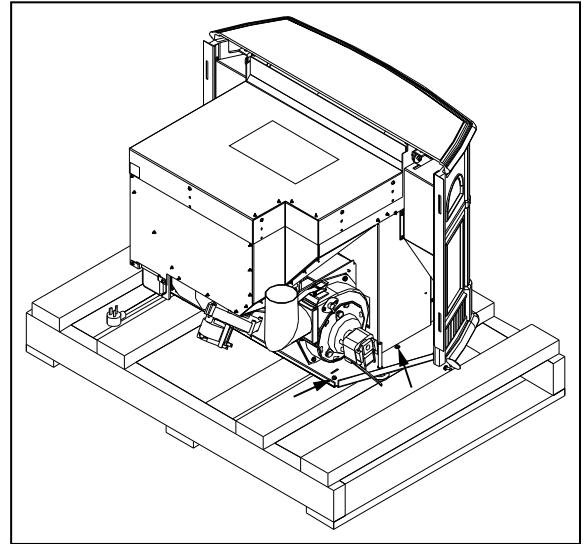

Figure 1: Removing Stove From the Pallet.

## DIMENSIONS:

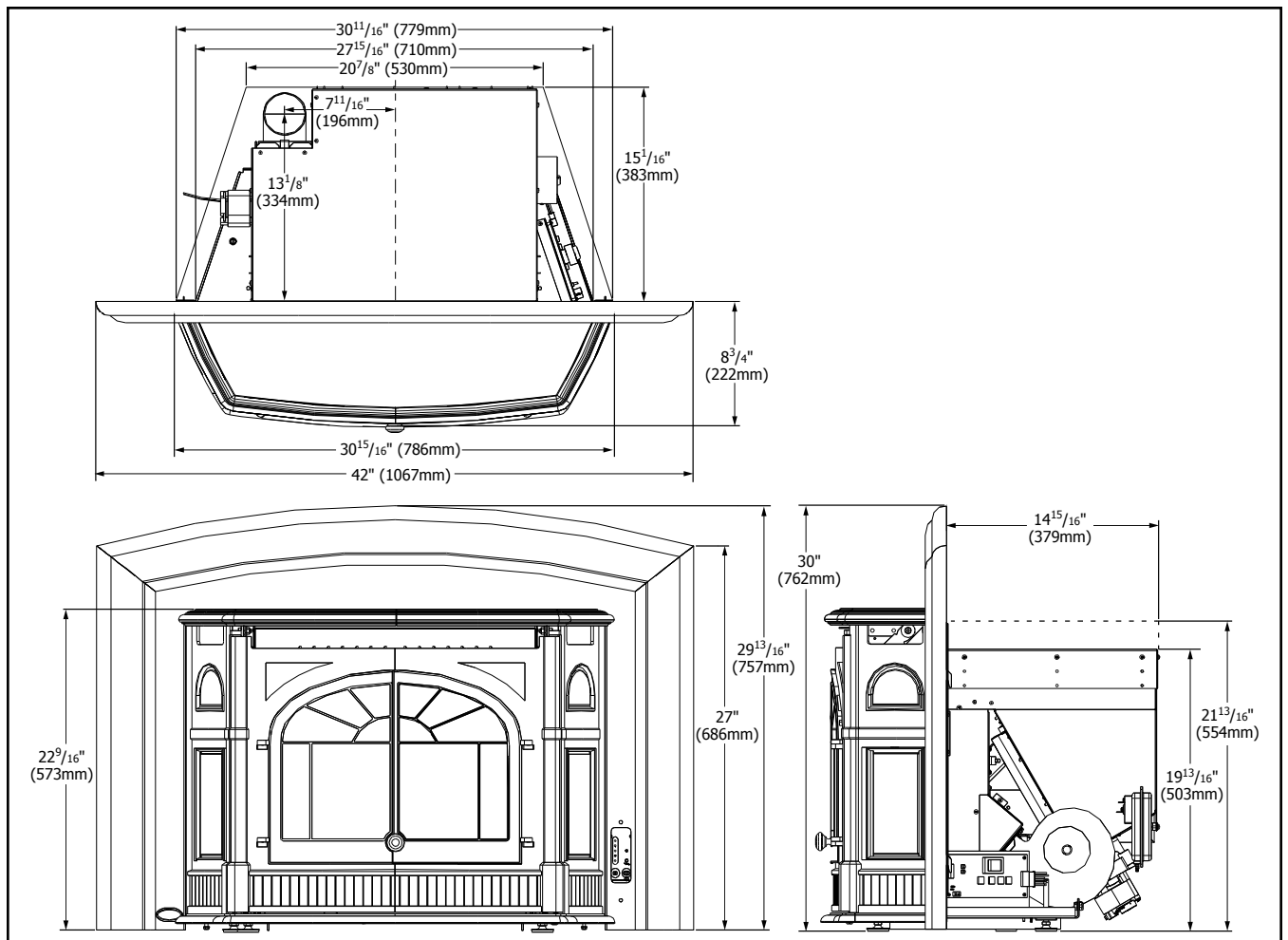

Figure 2: Dimensions of Empress Fireplace Insert.

# INSTALLATION

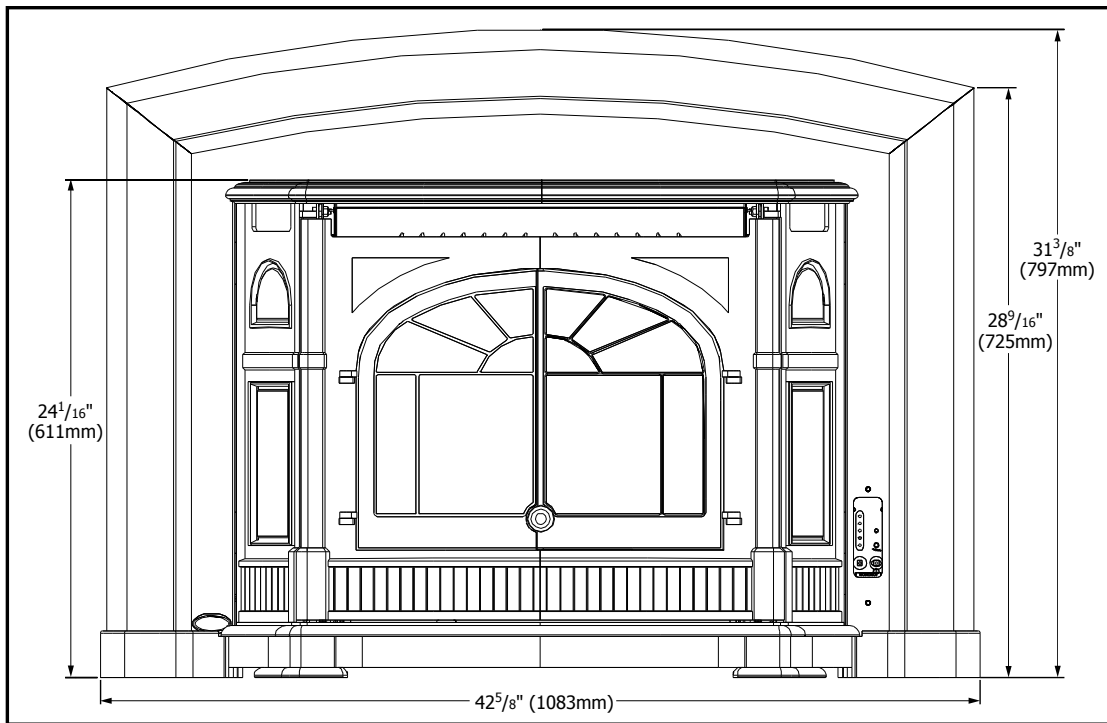

Figure 3: Dimensions of Empress Fireplace Insert with Optional Skirt.

## CLEARANCES TO COMBUSTIBLES:

Refer to Figure 4.

Side wall to center of unit 24 inches (61.0 cm)

Side wall to surround 3 inches (7.6 cm)

Mantel projection 12 inches (30.5 cm)

Mantel to bottom of unit 36 inches (91.4 cm)

Top facing to unit 0 inches (0 cm)

Side facing to unit 0 inches (0 cm)

The floor 6 inches (15.2 cm) on either side of the unit and to the front must be protected by a non-combustible material.

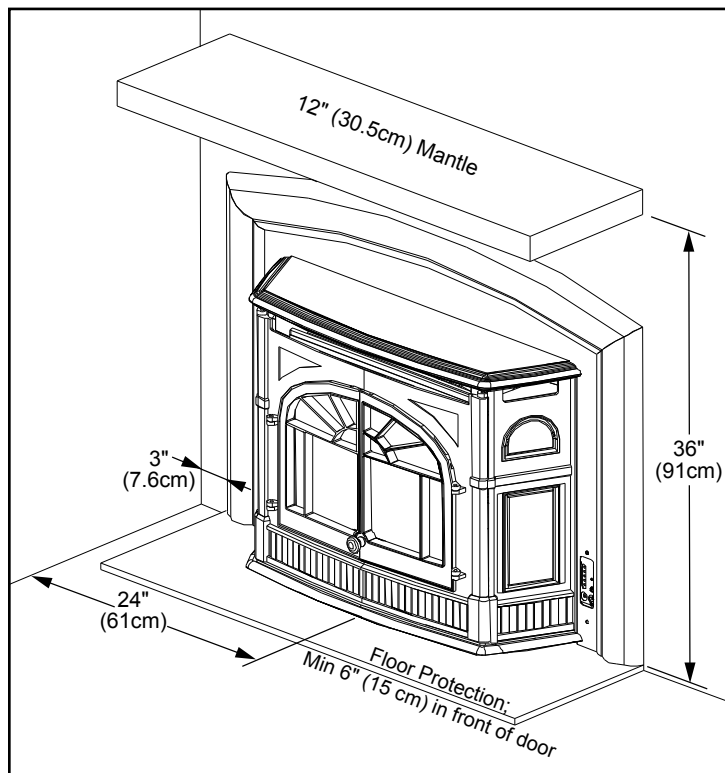

Figure 4: Empress FPI Clearance to Combustibles.

# INSTALLATION

## MASONRY FIREPLACE INSTALLATION:

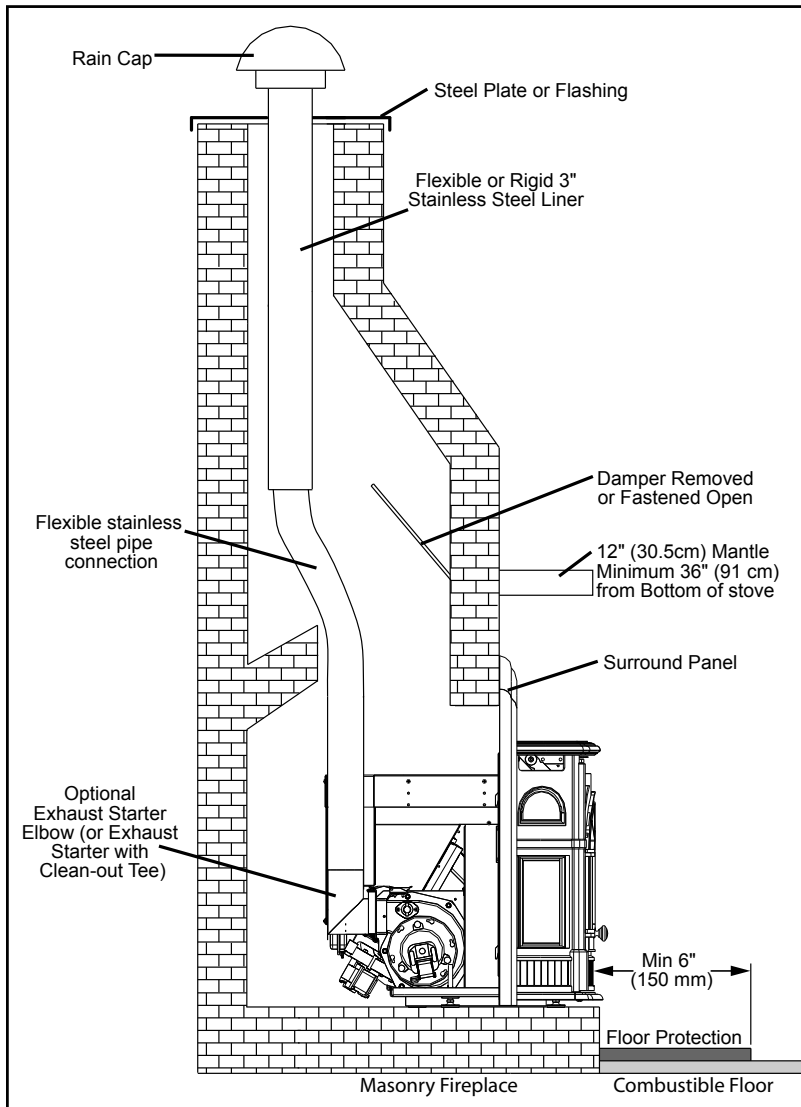

Figure 5: Masonry fireplace installation without skirt.

When installing the insert into a masonry fireplace, **DO NOT** remove any bricks or masonry, with the following exception: masonry or steel, including the damper plate, may be removed from the smoke shelf and adjacent damper frame, if necessary, to accommodate a chimney liner. Do this only if their removal will not weaken the structure of the fireplace and chimney, and will not reduce protection for combustible materials to less than that required by the national building code. When installing the fireplace insert into a zero clearance fireplace, **DO NOT** cut or modify any factory firebox parts.

If installing the Empress with a skirt the skirt must be installed before the installation.

A non-combustible hearth pad must cover combustible flooring underneath, as well as 6" (150 mm) in front of the heater and 6" (150 mm) to the side of the heater.

1. Install the hearth pad.
2. Lock the fireplace damper in the open position.
3. Install a positive flue connector at the fireplace damper.
4. Set leveling leg to approximate height.
5. Connect a Exhaust Starter Quick Connect, straight or elbow, to the exhaust pipe.
6. This fireplace insert must be installed with a continuous chimney liner of 3" or 4" diameter extending from the fireplace insert to the top of the chimney. The liner must conform to type 3 requirements of CAN/ULC S635.

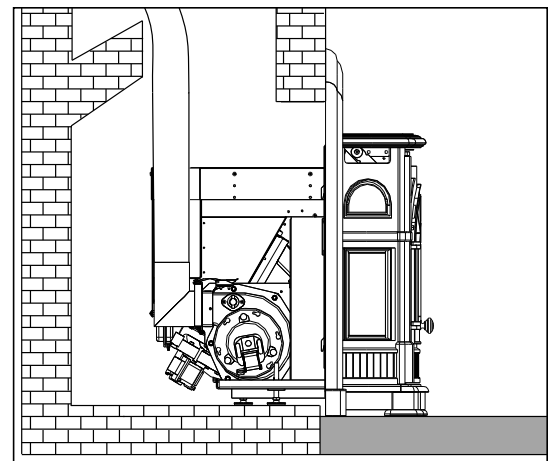

Figure 6: Masonry fireplace installation with skirt.

# INSTALLATION

## POSITIVE FLUE CONNECTION WITHOUT A FULL RELINE (USA ONLY):

This unit does not require a full reline (in USA only) when installing into a masonry fireplace, however, it is recommended to ensure proper drafting of the appliance.

**IMPORTANT:** Ensure the chimney and firebox are cleaned and free of all debris, including soot and ashes, before proceeding with this installation. If it is not clean soot maybe blown into the room through the unit's blower. Ensure the fireplace and chimney have not deteriorated in any way. If there is any sign of corrosion or damage in the chimney the unit can not be installed. This unit can be installing in a masonry fireplace built to (UBC 37 or ULC S628 standards) or a factory built fireplace (built to UL 127 or ULC S610 standards).

1. If installing the Empress with a skirt, the skirt must be installed before the installation.
2. Install the hearth pad. The floor 6" (150 mm) in front of the unit and 6" (150 mm) to each side of the unit must be protected with a non-combustible hearth pad.
3. The vent connector from the insert must extend a minimum of 18" above the chimney seal plate. The chimney seal plate area must be sealed to prevent the exhaust from the chimney from coming

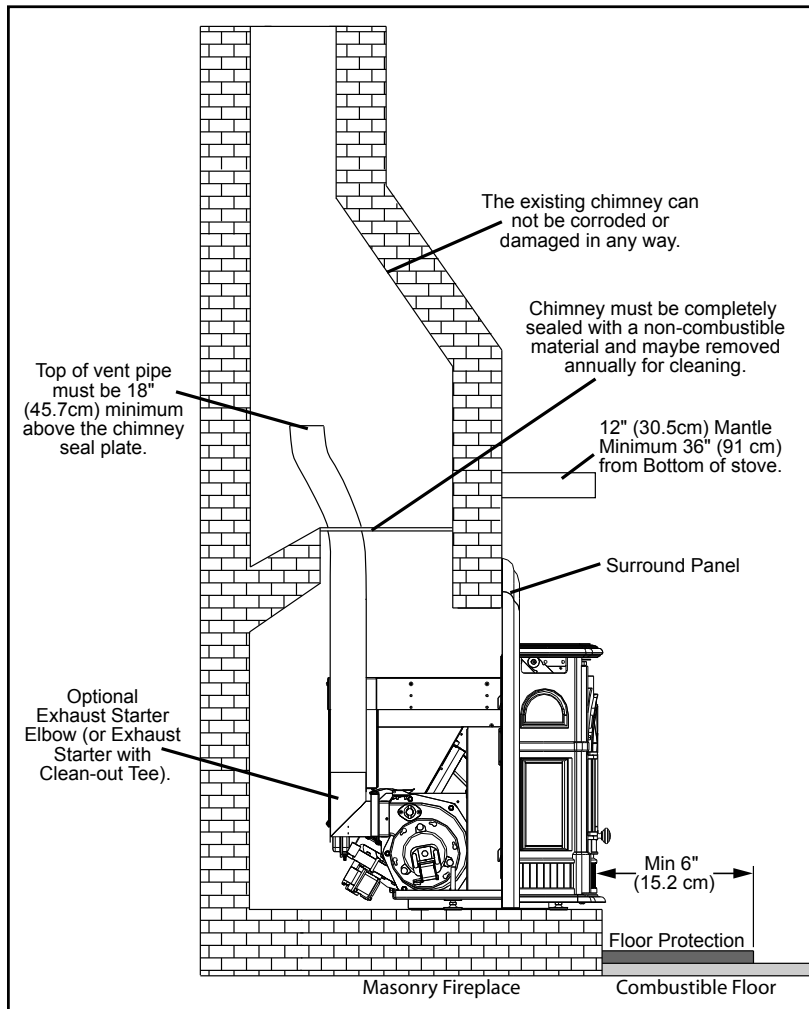

Figure 7: Masonry fireplace positive flue installation.

back into the fireplace and prevent air from the fireplace from entering the chimney which will affect proper drafting of appliance.

A qualified installer should evaluate the existing fireplace to determine the best method for achieving a positive flue connection between the vent pipe or liner and the chimney. Whatever method used must effectively seal the area to prevent room air passage to the chimney cavity of the fireplace. A couple examples of Approved Methods of Achieving a Positive Flue Connection are:

- a) Secure a seal-off plate (i.e. 22-gage sheet steel) in the masonry fireplace throat using masonry screws.
- b) Pack non-combustible material (i.e. rockwool) around the vent pipe or using a flue adapter.

4. Set leveling leg to approximate height.
5. Connect the Exhaust Starter Quick Connect, straight or elbow, to the exhaust pipe.

**IMPORTANT:** The chimney seal plate must be removed for the annually chimney cleaning as ash will build up on top of the plate.

# INSTALLATION

## ADJUSTING HOPPER HEIGHT:

The back height of this unit can be set to one (1) of three (3) heights; 19<sup>13/16</sup>" (503 mm), 20<sup>13/16</sup>" (529 mm), 21<sup>13/16</sup>" (554 mm). The hopper should be set to the maximum height that can be used in the installation.

To change the height of the hopper up or down, remove the seven (7) T-20 screws, three (3) on each side and one (1) on the back. The screw placement is shown Figure 8. Move the hopper assembly to the required setting and replace the screws. When the hopper back is in place it is recommended that silicone is used to seal the bottom lip of the hopper back and sides.

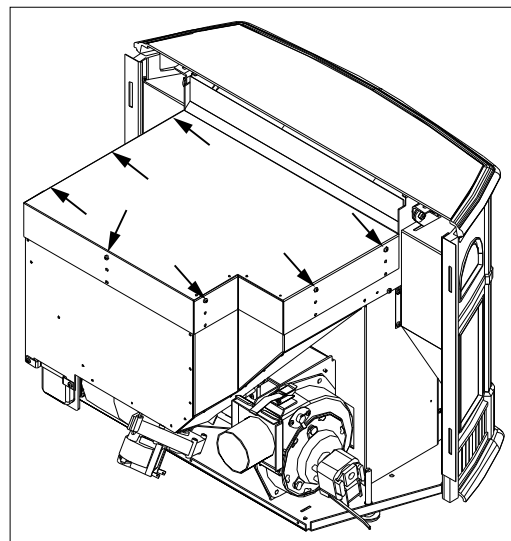

Figure 8: Screws to move hopper.

## INSTALLATION OF CAST SKIRT OPTION:

The cast skirt is a five (5) piece option that can be installed when the front of the Empress FPI is going to be lower than the back of the unit; ensure that none are damaged before you proceed.

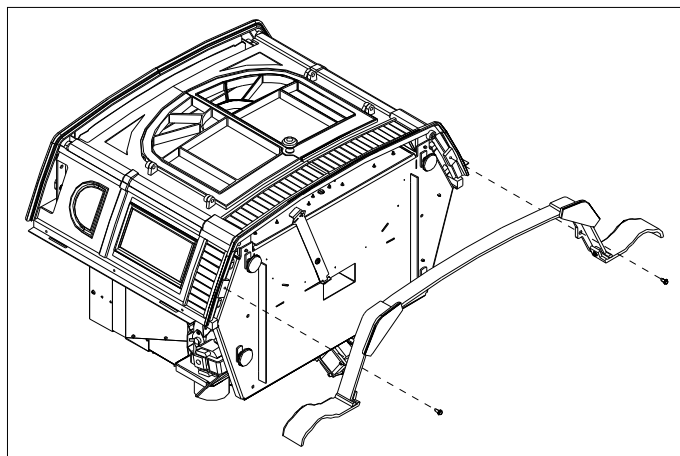

Figure 10: Installing Cast Skirt.

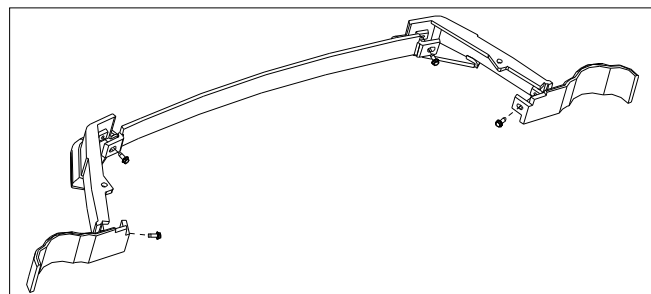

Figure 9: Assembling Cast Skirt.

1. Using a  $\frac{3}{8}$ " socket or wrench connect the five (5) pieces of the skirt together with four (4) screws provided (see Figure 9). Do not completely tighten the screws; the screws should be loose enough that the cast pieces will be able to be adjusted but not fall apart.
2. Gently put the Empress FPI on its back.
3. Using two (2) screws provided attach the cast skirt to the bottom of the unit as shown in Figure 10.

# INSTALLATION

## SURROUND PANEL INSTALLATION:

1. Lift the cast top, it will come up and forward.
2. Install the daughter board onto the right side of the surround panel onto the two (2) studs. Fasten into place with a wingnut on each stud.
3. Plug the wiring harness from the daughter board into the mother board.
4. Slide the surround panel behind the cast top and line up the two (2) hooks on either side on the surround panel with the slots on either side of the Empress FPI. Wiggle the surround to ensure the surround panel to the back of the surround panel.
5. Push cast top back into place.

## REMOVAL:

When maintenance is required on the unit the surround must be removed.

1. Lift the cast top, it will come up and forward.
2. Lift the surround panel up and out.

## THERMOSTAT INSTALLATION:

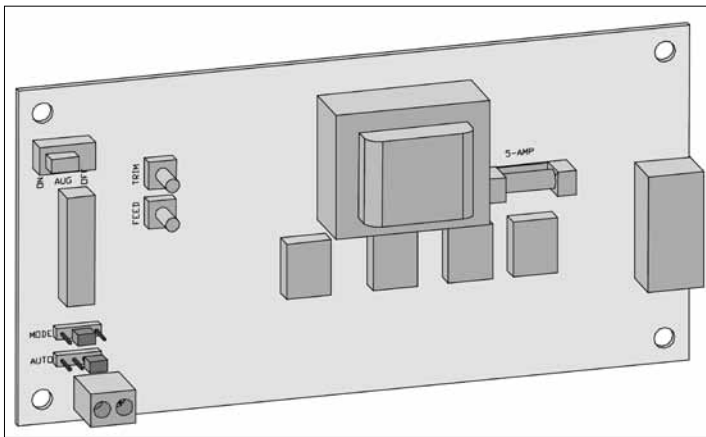

Figure 11: Mother Board.

This control board can be placed into three (3) different modes: Full Auto ON/OFF, High/Low Thermostat or Manual Mode. From the factory the far right AUTO pins are jumped and the control board is in manual mode operation (see Figure 12). If the far left AUTO pins are jumped the circuit board is in Full Auto ON/OFF mode (see Figure 13). When the center AUTO pins are jumped the unit is in the HI / LOW thermostate mode (see Figure 14), the unit will be taken to a low or idle setting when the thermostat is not calling for heat. When the thermostat calls for heat, the unit will go to the setting that is displayed on the control board Heat Indicator.

1. Install the wall thermostat in a location that is not too close to the unit but will effectively heat the desired area.
2. Install a 12 or 24 Volt Thermostat using an 18 x 2 gauge wire from the unit to the thermostat.

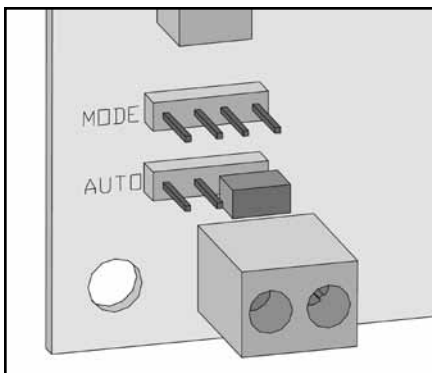

Figure 12: Auto pins set-up MANUAL.

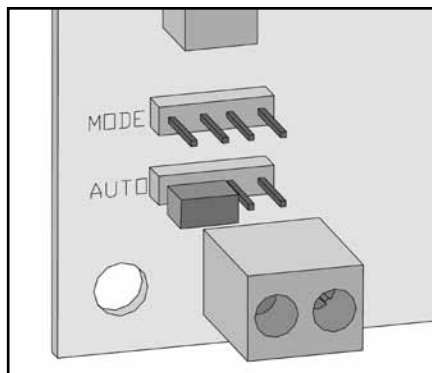

Figure 13: Auto pins set-up ON/OFF.

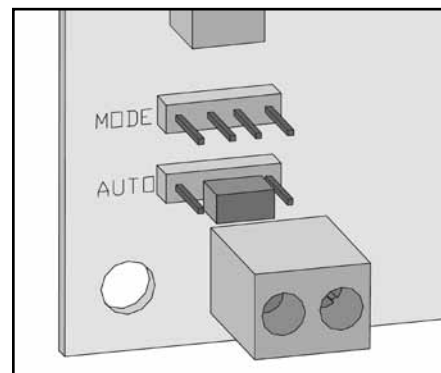

Figure 14: Auto pins set-up HI/LOW.

# INSTALLATION

## SLIDER/DAMPER SETTING:

This is used to regulate the airflow through the pellet stove.

**THE SLIDER / DAMPER MUST BE SET AT TIME OF INSTALLATION.**

**A Qualified Service Technician or Installer must set the Slider Damper.**

The slider damper is located behind the cast doors and under the firebox.

- If the fire should happen to go out and the heat output indicator has been set on the lowest setting, the Slider Damper should be moved to the left slightly, lessen the air flow into the firebox.
- If, after long periods of burning, the fire builds up and overflows the burn pot or there is a build up of clinkers, this would be a sign that the pellet quality is poor, this requires more primary air, the slider damper must be moved to the right to give the fire more air.

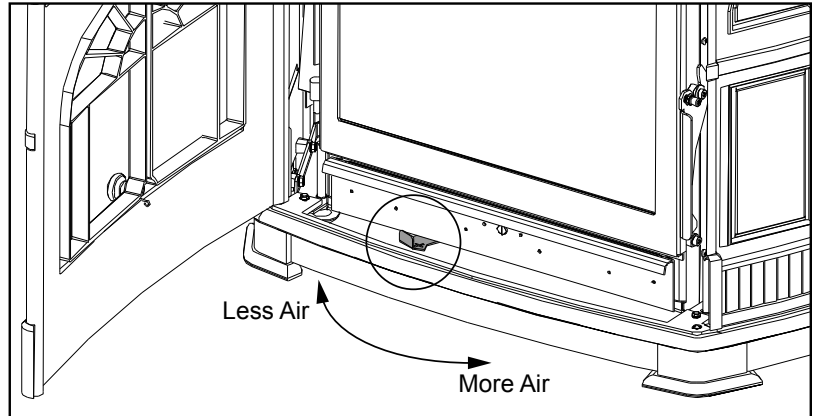

Figure 15: Slider / damper positions.



Figure 16: Efficient Flame.

The easiest way to make sure that an efficient flame is achieved is to understand the characteristics of the fire.

- A tall, lazy flame with dark orange tips requires more air – Push Right
- A short, brisk flame, like a blowtorch, has too much air – Push Left
- If the flame is in the middle of these two characteristics with a bright yellow/orange, active flame with no black tips then the air is set for proper operation.

The combustion exhaust blower is a variable speed blower controlled by the heat output setting. This blower will increase or decrease the blower speed as the heat output setting is turned up or down.

## SPECIAL NOTES:

Pellet quality is a major factor in how the pellet stove will operate. If the pellets have a high moisture content or ash content the fire will be less efficient and has a higher possibility of the fire building up and creating clinkers (hard ash build-up). If this happens, move the Slider / Damper to the right slightly to increase the air flow to the fire.

Taking a reading of vacuum pressure inside the firebox with a magnehelic gauge can be used to set the slider for best combustion. **The best settings are a reading of 0.12 to 0.13 inches of water column (30 Pa) on the high fire setting. Some fuels may require higher or lower settings.** The reading can be taken from the 1/8" (3 mm) hole located on the front of the unit below the door in the ash pan front.

# TROUBLESHOOTING

---

## DO NOT:

- Service the stove with wet hands. The stove is an electrical appliance, which may pose a shock hazard if handled improperly. Only qualified technicians should deal with possible internal electrical failures.
- Do not remove from the firebox any screws without penetrating oil lubrication.
- Hold the ON / OFF BUTTON down. This is a momentary contact switch and can be damaged if held down too long.

## WHAT TO DO IF:

1. The stove will not start.
2. The stove will not operate when hot.
3. The exhaust blower will not function normally.
4. Light # 2 on Heat output bar flashing.
5. The auger motor will not function normally.
6. The 200 °F (93 °C) high limit temperature sensor has tripped.
7. The convection blower will not function normally.
8. Ignitor- the pellets will not light.
9. Control settings (Heat Level) has no effect on the fire.
10. The stove keeps going out.

**\*NOTE: All troubleshooting procedures should be carried out by qualified technicians or installers.**

### 1. The stove will not start.

- ✓ Make sure the stove is plugged in and the wall outlet is supplying power.
- ✓ Push the ON /OFF button. You may need to wait approximately 30 seconds for circuit board to initiate before the stove will turn on.
- ✓ If the control board has been placed in the on/off thermostat mode, then turn the thermostat up to call for heat.
- ✓ Check the heat level indicator. - If the # 2 light is flashing refer to section 4. Light # 2 on Heat output bar flashing.
- ✓ Check the fuse on the motherboard; nothing will work if the fuse is blown.
- ✓ If the unit still does not start, contact your local service dealer for service.

### 2. The stove will not operate when hot.

- ✓ Check the heat level indicator if a fire is not detected, or if the fire has gone out **the #3 light will flash** because the exhaust temperature sensor's contacts have opened.
- ✓ Check the hopper for fuel.
- ✓ The burn pot liner may require cleaning. Build up in the burn pot will cause the unit to shut off by stopping the auger feed.
- ✓ Incorrect air damper setting. - Excessive air may consume the fire too quickly before the next drop of fuel, leaving completely unburned fuel in the burn pot liner. - Insufficient air will cause build up, further restricting the air flow through the burn pot liner. This in turn will cause the fuel to burn cold and very slowly. Fuel may build up and smother the fire. In this case clean the burn pot. **(Note: the unit may require a change to the vent system or installation of fresh air to correct air to fuel ratio problems).**
- ✓ Check the fuse on the motherboard; nothing will work if the fuse is blown.
- ✓ Combustion blower failure. - The combustion blower is not turning fast enough to generate the proper vacuum in the fire box. Visual check – is the blower motor turning.

# TROUBLESHOOTING

---

- ✓ Check the exhaust blower voltage across the blower wires ( $\geq 114V$  on #5 setting and  $\geq 82V$  on #1 setting). – Replace the Circuit Board if the Voltage reading is less than 82V. with a line voltage  $>115V$  AC.
- ✓ Check vacuum levels in the exhaust channel by bypassing the vacuum switch, then remove the vacuum hose from vacuum switch. Check the vacuum readings by placing the open end of the vacuum hose on a Magnahelic Gauge (readings must be above 0.07" W.C. (17.4 Pa) on low fire).
- ✓ Poor quality fuel – insufficient energy in the fuel to produce enough heat to keep the stove burning or operational.
- ✓ Exhaust temperature sensor failure. – Bypass sensor located on exhaust blower if stove now operates properly, the unit may require cleaning or a new sensor. Contact your local dealer for service.
- ✓ Contact your local dealer for service.

### **3. The exhaust motor will not function normally.**

- ✓ Open the left side access panel; check all connections against the wiring diagram.
- ✓ See "2. The stove will not operate when hot." Section.

### **4. Light # 2 on Heat output bar flashing**

(The 200 °F ( 93 °C) high limit temperature sensor has tripped.)

- ✓ Reset sensor and determine cause – was it a convection blower failure? Test by connecting it directly to power.

**To reset Circuit Board after a trouble code - push the ON/OFF button**

### **5. The auger motor will not function normally.**

- ✓ The burn pot liner may require cleaning. Build up in the burn pot will cause the unit to shut off.
- ✓ Check for obstructions in the hopper system.
- ✓ Ensure door is closed and ash pan is closed. The auger motor will stop if there is not enough vacuum in the stove.
- ✓ Pinch, break or blockage in vacuum hose - check hose for pinch points or damage, replace or re-route as required. Blow out vacuum hose
- ✓ Blocked exhaust / venting system - have stove and venting cleaned and inspected.
- ✓ Severe negative pressure in area where unit is installed - check the operation by opening a window, does this solve the problem? If it does, install fresh air intake to unit or room. Venting system may require vertical section to move termination into a low pressure zone.
- ✓ Vacuum switch failure - bypass the vacuum switch, if this corrects the problem check for above problems before replacing the vacuum switch.
- ✓ Damage to orange wires between circuit board and vacuum switch - inspect wires and connectors
- ✓ Combustion blower failure - the combustion blower is not turning fast enough to generate the proper vacuum in the exhaust channel. Visual check; is the blower motor turning? Check the exhaust blower voltage across the blower wires ( $\geq 114V$  on #5 setting and  $\geq 82V$  on #1 setting). – Replace the circuit board if the Voltage reading is less than 82V. with a line voltage  $>114V$  AC.
- ✓ Check vacuum levels by bypassing the vacuum switch, then remove the Vacuum hose from Vacuum Switch. Check vacuum readings by placing the open end of the Vacuum Hose on a Magnahelic Gauge. (readings must be above .07" W.C. on low fire).
- ✓ Call your local dealer for service.

# TROUBLESHOOTING

---

Auger light flashes but auger motor does not turn at all.

- ✓If the auger gear box does not turn but the motor's armature does try to spin then the auger is jammed.
  - Try to break apart jam by poking at the jam through the drop tube. If this fails then empty the hopper and remove the auger cover **\*\*remember to re-seal the cover after installation\*\***
- ✓Check the fuse on the motherboard; nothing will work if the fuse is blown.

## **6. The convection blower will not function normally.**

- ✓Clean all grill openings at the back and below unit as well as the fan blades.
- ✓Contact your local dealer for service.

## **7. Ignitor- the pellets will not light.**

(Everything else in the stove operates but the ignitor will not light the pellets.)

- ✓Make sure the burn pot liner is up tight and square to the ignitor tube by pushing the burn pot back against the ignitor tube.
- ✓Check to see if the exhaust blower is operating. If not, contact your local dealer for service.

**NOTE:** The ignitor should be bright orange in color after about five (5) minutes. If not replace the ignitor.

## **8. Control settings (Heat Level) has no effect on the fire.**

- ✓Note: If the system light is flashing the control board has complete control of the unit. When the units system light becomes solid then control of the unit is given back to the operator.
- ✓If there is no control of the heat level button make sure the thermostat is calling for heat.
- ✓Call your local dealer for service.

## **9. The stove keeps going out.**

**a)** If the stove goes out and leaves fresh unburned pellets or cigarette-like ashes in the burn pot liner, the fire is going out before the stove shuts off.

- ✓Check Ash build-up in the burn pot can make the auger stop. Increase the air by moving the slider to the right.
- ✓Check to see that the slider / damper is in the correct position.
- ✓Turn the heat level up slightly (poor quality pellets will require slightly higher settings).
- ✓Set the auger trim till the #1 and #5 lights are illuminated.

**b)** If the stove goes out and there are partially burned pellets left in the burn pot liner, the stove has shut down due to a lack of air, exhaust temperature, or power failure.

- ✓Adjust the slider / damper.
- ✓Check to see if the stove needs a more complete cleaning.
- ✓Turn the heat level up slightly (poor quality pellets will require slightly higher settings).
- ✓Did the power go out?
- ✓Contact your local dealer for service.

# WIRING DIAGRAM

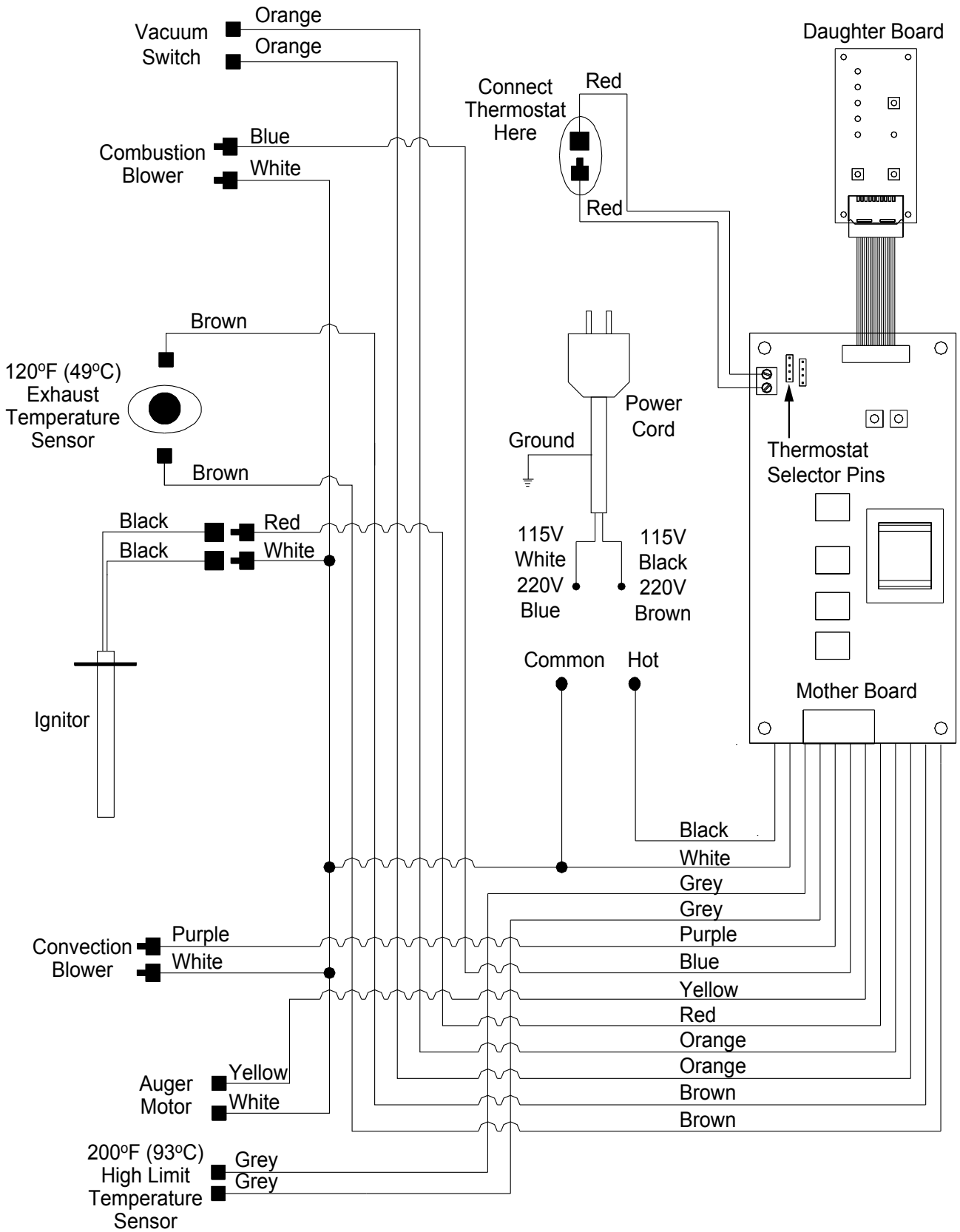

## PARTS LIST

---

Reference Number	Description	Part Number
1	120 °F (49 °C) Ceramic Fan Temperature Sensor	EC-001
	Domestic Power Cord - 115V	EC-042
2	Auger Motor - 115V	EF-001
3	High Limit Temp Sensor 200 °F (93 °C) Manual Reset	EF-016
	Silicone Hose	EF-018
4	Ash Pan Latch	EF-060
	Pellet Stove Cleaning Brush	EF-156
5	Convection Blower - 115V	EF4i-002
	Door Screen	50-177
6	Brick Panel Retainers (set of 2)	50-185
7	Door Knob - Brushed Nickel	50-262
8	Combustion/ Exhaust Blower - 115V	50-473
9	400 Watt Ignitor - 115V	50-619
	Dual bulb door gasket - 10 ft (3.05m)	50-634
	Hinge Pin - Silver	50-750
10	Circuit Board 5 Amp Fuses - 115V (Pair)	50-833
	5/8" ID Auger Collar with Screw	50-968
11	Auger - 115 V	50-1346
12	Auger Plate with Bushing	50-1359
13	Burn Pot - 1.5" Intake Hole	50-1366
	Empress FPI Domestic Owner's Manual - 115V	50-1385
	Empress FPI Domestic Technical Manual - 115V	50-1386
14	Vacuum Switch - Low Pressure	50-1390

# PARTS LIST

---

Reference Number	Description	Part Number
15	Exhaust Starter Tube 3" Quick Connect	50-1391
16	Mother Board - 120V	50-1392
17	Daughter Board - 120V	50-1393
18	Slider Damper & Lever	50-1394
19	Exhaust Starter Elbow Quick Connect	50-1395
20	Exhaust Starter Gasket	50-1396
21	Daughter Board Decal	50-1397
22	Ignitor & Intake Tube	50-1398
23	Cast Brick Panel Set	50-1399
24	Inner Door Complete with Glass & Tape	50-1400
25	Burn Pot Liner with Sides	50-1401
26	Door Bolt, Hardened Bushing & Nut	50-1465
27	Inner Door Handle	50-1467
28	Glass With Tape	50-1468
29	Empress FPI Cast Surround Panel - Painted	50-1258
29	Empress FPI Cast Surround Panel - Diamond Black	50-1260
29	Empress FPI Cast Surround Panel - Antique Chestnut	50-1261
30	Empress FPI Cast Skirt - Painted	50-1262
30	Empress FPI Cast Skirt - Diamond Black	50-1264
30	Empress FPI Cast Skirt - Antique Chestnut	50-1265
31	Empress FPI Oversized Filler Surround Panel	50-1348
32	Empress FPI Casting Complete - Painted	50-1403
32	Empress FPI Casting Complete - Diamond Black	50-1404
32	Empress FPI Casting Complete - Antique Chestnut	50-1405

# PARTS DIAGRAM - COMPONENTS



## Empress - Fireplace Insert Components

October 2006

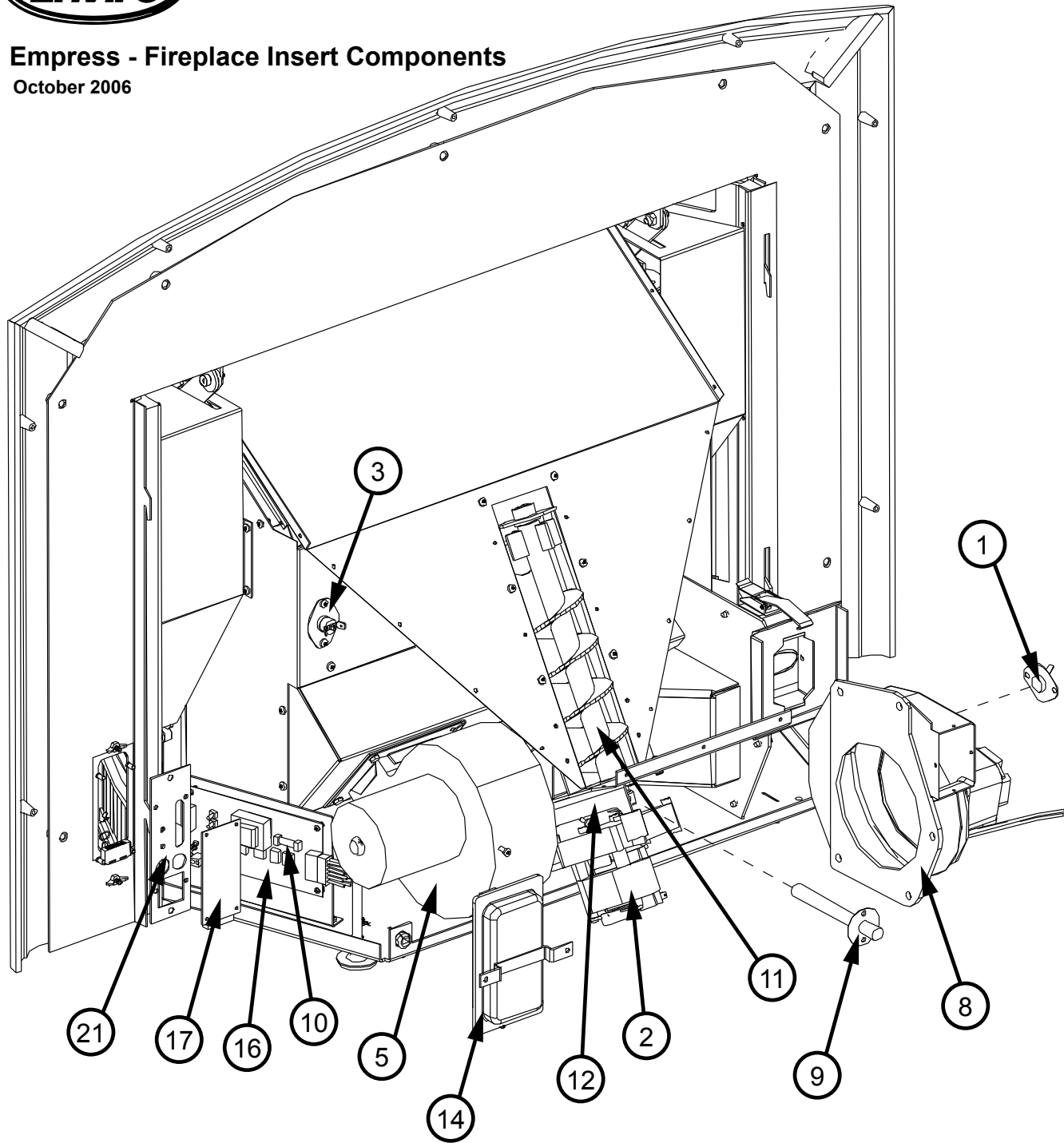

# PARTS DIAGRAM - PARTS

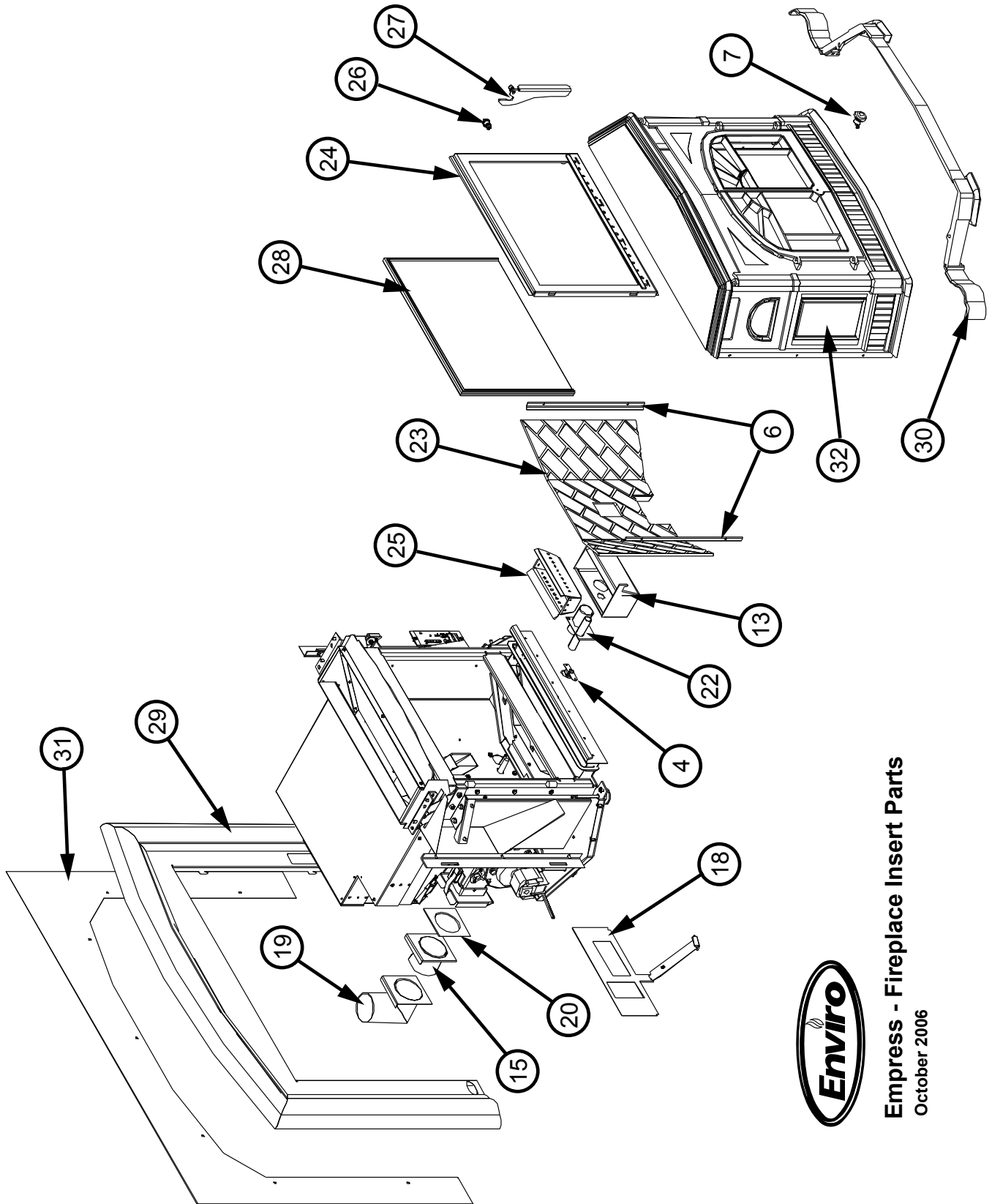

**Empress - Fireplace Insert Parts**  
October 2006

# WARRANTY

---

Sherwood Industries Ltd. is the manufacturer of the Enviro line of heating products. At Sherwood Industries, our commitment to the highest level of quality and customer service is the most important thing we do. Each Enviro stove is built on a tradition of using only the finest materials and is backed by our Exclusive Lifetime Limited Warranty to the original purchaser. With Enviro, you're not just buying a stove, you're buying a company with years of unequalled performance and quality.

## **Limited Lifetime Warranty:**

Under this warranty, Sherwood Industries Ltd. covers the fireplace or stove body and accessories against defects in materials and workmanship, for part repair or replacement for the first seven (7) years and limited labour for the first two (2) years to the original purchaser. This Warranty covers: Firebox, Heat Exchanger, Burn Pot, Firebox Panels, Ceramic Glass, Pedestals, Panels, Legs, and Door Assembly. Please see the exclusions and limitation section below as certain restrictions and exclusions apply to this warranty.

## **Limited Three (3) Year Warranty**

Under this warranty, Sherwood Industries Ltd. covers the Burn Pot Liner and Log Sets against defects in materials and workmanship, for part repair or replacement for the first three (3) years and limited labour for the first two (2) years to the original purchaser. Please see the exclusions and limitation section below as certain restrictions and exclusions apply to this warranty.

## **Limited Two (2) Year Warranty:**

Under this warranty, Sherwood Industries Ltd. covers: Ignitor, Auger Motor, Circuit Board, Timers, Temp Sensors, Blowers, Vacuum Switch and Wire Harness, against defects in materials and workmanship, for part repair or replacement for the first two (2) years and limited labour for the first two (2) years to the original purchaser. Please see the exclusions and limitation section below as certain restrictions and exclusions apply to this warranty.

## **Limited One (1) Year Warranty:**

Under this warranty, Sherwood Industries Ltd. covers all exterior surface finishes against defects in materials and workmanship, for part repair or replacement and limited labour for the first (1) year to the original purchaser. Please see the exclusions and limitation section below as certain restrictions and exclusions apply to this warranty.

## **Here is how our Warranty works**

If you have any concerns with your Enviro product please contact the dealer where you purchased the fireplace or stove. Your dealer shall make all claims under this warranty in writing.

## **To the Dealer**

When filling out a warranty claim please complete the following information on an official warranty claim form:

Customer information: Name, address and telephone number of purchaser and date of purchase.

Dealer information: Date of installation, name of installer and dealer, serial number of the appliance, nature of complaint, defects or malfunction, description and part numbers of any parts replaced.

## **To the Distributor**

Sign and verify that work and information are correct.

# WARRANTY

---

## **Exclusions and Limitations:**

1. This Warranty does not cover tarnish, discoloration or wear on the plating or paint.
2. This Warranty excludes wear and tear or breakage caused by cleaning, moving or service on log set.
3. A qualified installer must install this stove or fireplace. This Limited Warranty covers defects in materials and workmanship only if the product has been installed in accordance with local building and fire codes; in their absence, refer to the owner's manual. If the product is damaged or broken as a result of any alteration, willful abuse, mishandling, accident, neglect, or misuse of the product, the Limited Warranty does not apply.
4. The stove must be operated and maintained at all times in accordance with the instructions in the Owner's Manual. If the unit shows signs of neglect or misuse, it is not covered under the terms of this Warranty policy. Performance problems due to operator error will not be covered by the Limited Warranty policy.
5. As this is a heating appliance some changes in colour of surface finishes may occur. This is not a flaw and as such is not covered under this warranty.
6. Some minor expansion, contraction, or movement of certain parts and resulting noise, is normal and not a defect and, therefore, is not covered under this Limited Warranty.
7. Misuse includes over-firing. Over-firing this appliance can cause serious damage and will nullify the Limited Warranty.
8. The Limited Warranty will cover glass thermal breakage only and will not cover misuse of the stove glass, including but not limited to glass that is struck, has surface contaminates or has had harsh or abrasive cleaners used on it.
9. This warranty does not cover products made or provided by other manufacturers and used in conjunction with the operation of this stove without prior authorization from Sherwood Industries Ltd. The use of such products may nullify the Limited Warranty on this stove. If unsure as to the extent of this Limited Warranty, contact your authorized Enviro dealer before installation.
10. Sherwood Industries Ltd. will not be responsible for inadequate performance caused by environmental conditions.
11. The Limited Warranty does not cover installation and operational related problems such as spillage caused by environmental conditions. Environmental conditions include but are not limited to nearby trees, buildings, roof tops, wind, hills, mountains, inadequate venting or ventilation, excessive offsets, negative air pressures or other influences caused by mechanical systems such as furnaces, fans, clothes dryers etc.
12. The Limited Warranty is void if:
  - a) The stove has been operated in atmospheres contaminated by chlorine, fluorine or other damaging chemicals.
  - b) The stove is subject to submersion in water or prolonged periods of dampness or condensation.
  - c) Any damage to the unit, combustion chamber or other components due to water, or weather damage which is the result of, but not limited to, improper chimney/venting installation.
  - c) Salt air in coastal areas or high humidity can be corrosive to the finish; these environments can cause rusting. Damage caused by salt air or high humidity is not covered by the Limited Warranty.
13. Exclusions to the Limited Warranty include: injury, loss of use, damage, failure to function due to accident, negligence, misuse, improper installation, alteration or adjustment of the manufacturer's settings of components, lack of proper and regular maintenance, alteration, or act of God.
14. The Limited Warranty does not cover damage caused to the fireplace or stove while in transit. If this occurs, do not operate the stove and contact your courier and/or dealer.
15. The Limited Warranty does not extend to or include firebox paint, door or glass gaskets with damage caused by normal wear and tear, or exterior paint discoloration or chipping, worn gaskets, etc.
16. The Limited Warranty does not include damage to the unit caused by abuse, improper installation, or modification of the unit.

# WARRANTY

---

17. Damage to plated surfaces caused by fingerprints, scratches, melted items, or other external scores and residues left on the plated surfaces from the use of abrasive cleaners or polishes is not covered in this warranty.
18. The Limited Warranty does not cover tarnish, discoloration or wear on the plated surfaces.
19. The paint on the Metal Brick Liner may peel. This is due to the extreme conditions applied to the paint during normal usage. It is not a flaw and is not covered under warranty.
20. Sherwood Industries Ltd. is free of liability for any damages caused by the fireplace or stove, as well as inconvenience expenses and materials. The Limited Warranty does not cover incidental or consequential damages.
21. The Limited Warranty does not cover any loss or damage incurred by the use or removal of any component or apparatus to or from the Enviro fireplace or stove without the express written permission of Sherwood Industries Ltd. and bearing a Sherwood Industries Ltd. label of approval.
22. Any statement or representation of Enviro products and their performance contained in Enviro advertising, packaging literature, or printed material is not part of the Limited Warranty.
23. The Limited Warranty is automatically voided if the fireplace or stove's serial number has been removed or altered in any way. If the stove is used for commercial purposes, it is excluded from the Limited Warranty.
24. No dealer, distributor, or similar person has the authority to represent or warrant Enviro products beyond the terms contained within the Limited Warranty. Sherwood Industries Ltd. assumes no liability for such warranties or representations.
25. Sherwood Industries Ltd. will not cover the cost of the removal or re-installation of the stove, hearth, facing, mantels, venting or other components.
26. Labour to replace or repair items under this Limited Warranty will be covered per our warranty service fee reimbursement schedule. Labour rates are set per component and as such total labour costs may not be covered.
27. Sherwood Industries Ltd. is not liable for freight or labour on any stove replaced in-field and is not liable for travel costs for service work. In the event of in-home repair work, the customer will pay any in-home travel fees or service charges required by the Authorized Dealer.
28. At no time will Sherwood Industries Ltd. be liable for any consequential damages which exceed the purchase price of the unit. Sherwood Industries Ltd. has no obligation to enhance or modify any stove once manufactured (example: as a stove evolves, field modifications or upgrades will not be performed).
29. This Limited Warranty is applicable only to the original purchaser and it is non-transferable.
30. This warranty only covers Enviro products that are purchased through an authorized Enviro dealer.
31. If for any reason any section of the Limited Warranty is declared invalid, the balance of the warranty remains in effect and all other clauses shall remain in effect.
32. The Limited Warranty is the only warranty supplied by Sherwood Industries Ltd., the manufacturer of the stove. All other warranties, whether express or implied, are hereby expressly disclaimed and purchaser's recourse is expressly limited to the Limited Warranty.
33. Sherwood Industries Ltd. and its employees or representatives will not assume any damages, either directly or indirectly, caused by improper usage, operation, installation, servicing or maintenance of this stove.
34. Sherwood Industries Ltd. reserves the right to make changes without notice. Please complete and mail the warranty registration card and have the installer fill in the installation data sheet in the back of the manual for warranty and future reference.
35. Sherwood Industries Ltd. is responsible for stocking parts for a maximum of seven (7) years after discontinuing the manufacture or incorporation of the item into its products. An exception to this would be if an OEM supplier is not able to supply a part.

# INSTALLATION DATA SHEET

The following information must be recorded by the installer for warranty purposes and future reference.

NAME OF OWNER: \_\_\_\_\_

ADDRESS: \_\_\_\_\_  
\_\_\_\_\_  
\_\_\_\_\_

PHONE: \_\_\_\_\_

NAME OF DEALER: \_\_\_\_\_

ADDRESS: \_\_\_\_\_  
\_\_\_\_\_  
\_\_\_\_\_

PHONE: \_\_\_\_\_

MODEL: \_\_\_\_\_

SERIAL NUMBER: \_\_\_\_\_

DATE OF PURCHASE: \_\_\_\_\_ (dd/mm/yyyy)

DATE OF INSTALLATION: \_\_\_\_\_ (dd/mm/yyyy)

MAGNEHELIC AT INSTALL: \_\_\_\_\_

INSTALLER'S SIGNATURE: \_\_\_\_\_  
\_\_\_\_\_

NAME OF INSTALLER: \_\_\_\_\_

ADDRESS: \_\_\_\_\_  
\_\_\_\_\_  
\_\_\_\_\_

PHONE: \_\_\_\_\_

MANUFACTURED BY:  
SHERWOOD INDUSTRIES LTD.  
6782 OLDFIELD RD. SAANICHTON, BC, CANADA V8M 2A3  
[www.envirofire.biz](http://www.envirofire.biz)  
March 1, 2010  
C-12148