



G<9FKCC8:B8IGHF:9G:G'5B'9BJ:FCBA9BH5@M'F9GDCBG:6@9'7CAD5BM'H<:G'A5B15@:G'DF:BH98'CB'F97M7@98'D5D9F'
 D@95G9'?99D'H<9G9'BGHFI7HCBG:CF:IHI F9'F9:9F9B79



EG28 BV

BY: SHERWOOD INDUSTRIES LTD

OWNER'S MANUAL



WHAT TO DO IF YOU SMELL GAS

i 'CdYb'k]bXck g#9I h]b[i]g\ 'UbmcdYb'ÚUa Y"
 i '8c' bchifmhc'']\ h'UbmUdd']UbW"
 i '8c' bch'hcI W\ 'UbmY'VMf]W' gk]hW' cf' i gY' Ubm
 d\cbY']b'nci f'Vi]X]b["
 i ' =a a YX]UHY'mi W' ncI f' [Ug' gi dd']Yf' Zfca ' U'
 bY] [\Vci f]g' d\cbY'' : c`ck ' hY' [Ug' gi dd']Yf]g'
]bgfi W]cbg"
 i '=Znci ' W]bbch'fYUW' ncI f' [Ug' gi dd']Yfz' W' hY'
 ÚfY' XYdUfha Ybh'

H\]g' Udd']UbW' a UmVY']bgfU' YX']b' Ub' UZHYf' a Uf_Yh'
 dYfa UbYbhmicW]hYXz' a Ubi ZUM' fYX' fba cV]YÉ'
 \ca Yz'k \YfY' bchdfc\]V]hYX' Vm'cW' WéXYg'

H\]g' Udd']UbW']g'cb'mZcf' i gY' k]h' hY' hmdY' cZ [Ug'
]bX]W]hYX' cb' hY' fU]b[' d'UHY'' H\]g' Udd']UbW']g'
 bchWébj Yfh]VY' Zcf' i gY' k]h' chYf' [UgYg'z' i b'Ygg' U'
 Wfh]UYX']h]g' i gYX''

WARNING

If the information in this manual is not followed exactly, a fire or explosion may result causing property damage, personal injury or loss of life. Installation and service must be performed by a qualified installer, service agency or the gas supplier.

FOR YOUR SAFETY: Do not store or use gasoline or other Flammable vapours and liquids in the vicinity of this or any other appliance.



A UggUW'i gY]hg']bgfU' U]h'cbg' fK Ufb]b[É' H\]g' dfcXi Vm' a i gh' VY']bgfU' YX' Vm' U']WbgYX'
 d'i a VYf'cf' [Ug' ÚhYf' k \Yb']bgfU' YX' k]h']b' hY' 7ca a cbk YU'h' cZA UggUW'i gY]hg' CH'Yf'
 A UggUW'i gY]hg' WéXY' fYei]fYa Ybhg' : 'YI]VY' WébbYV]cf' a i gh' bch' VY' cb[Yf' h' Ub' ' *]b'z' U'
 g\i hcZZj Uj Y'a i ghVY']bgfU' YX' /cb'mX]fYV]ij YbhgYU'YX' Wéa Vi gh]cb' dfcXi V]g' UfY' Uddfcj YX'
 Zcf' VYXfcca g'U]h'fcca g' 5' W]fVcb' a cbcl]XY' XYh'V]cf']g' fYei]fYX']b' U' fcca g' WébhU]b]b['
 [Ug' ÚfYX' X]fYV]ij Ybh'Udd']UbW'g'

GUZYhmDf YWUi h]c b g

FOR SAFE INSTALLATION AND OPERATION OF YOUR “ENVIRO” HEATER, PLEASE CAREFULLY READ THE FOLLOWING INFORMATION:

i' 5''9BJ=F C [Ug' UfYX' Udd']UbWg'a i gh'VY']bgtU'YX']b'UWzfxUbW' k]h' h'Yf']bgtf' V]cbg''7UFYZ' ''mfYUX'U'' h'Y']bgtf' V]cbg']b' h']g'a Ubi U' U'fg' 7cbg' 'h' h'Y' Vi]X]b[' U' h'cf]m\Uj]b[' 7' f]gX]V]cb' h'c' XYH'fa]bY' h'Y' b'YX' Z'cf' U'dYfa]h' d'f]c'f' h'c' V'z'a a YbV]b[' h'Y']bgtU' U'h]cb''

i' '' **NOTE:** : U]i fY' h'c' Z'c''ck' h'Y'gY']bgtf' V]cbg' V'z'i' X' V]i' gY' U' a U'z' bV]cb' cZ' h'Y' U'fYd'UWz' k \]M' V'z'i' X' fYg' 'h']b' XYU'h'z' gYf]ci' g' VcX]m]b' 7' fr'z' UbX'#c'f' d'fcdYf'fm' XUa U]Y''

i' : U]i fY' h'c' Z'c''ck' h'Y'gY']bgtf' V]cbg' a Um'Ugc' j' c]X' n'ci' f' U'fY']bg' fUbW' UbX'#c'f' k UffU'bh'm'

• **To prevent injury, if the pilot or pilot and burners have gone out on their own, open the glass door and wait 5 minutes to air out before attempting to re-light the stove.**

i' 5'k Uhg' _YYd' h'Y' UfYU' U'fci' bX' h']g' Udd']UbW' V'WUf' cZV'z'a Vi gh'VY' a U'h'f]U'z' [Ug'c']bY' UbX' c'h'Y'f' U'Ua a U'VY']'ei']Xg' UbX' j' U'dci' fg''

i' H']g' Udd']UbW' g' l'ci' X' b'ch' VY' i' gYX' Ug' U' X'f'm]b[' fUW' Z'cf' V'z'h']b[' c'f' Z'cf' \Ub[]b[' 7' f]g'ra' Ug' g'rcW]b[g# XYV'z'fU'h]cbg''

i' 8i' Y' h'c' h'Y' dU]bh'W'f]b[' c'b' h'Y' g'rc' Y'z' U'Z]b'h'c'X'cf' UbX' g'] [\h' ga c_]b[' k]'']_Y'm' VY' b'ch'VWX' k \Yb' h'Y' g'rc' Y']g' U'fgh' gYX'' 'CdYb' U'k']bX'ck' i' b'h' h'Y' ga c_]b[' g'rc'dg''

5'k Uhg' V'z'bbYV'h' h']g' [Ug' g'rc' Y' h'c' U' j' Ybh' g'ng'h'a' UbX' j' Ybh' h'c' h'Y' c'i' h'g]XY' cZ' h'Y' Vi]X]b[' Ybj' Y'cdY'' B'Y' Yf' j' Ybh' h'c' Ub'ch'Y'f' f'cca' 'c'f']bg]XY' h'Y' Vi]X]b[' "A U_Y'g' fY' h'Y' g'd'V]U'YX' j' Ybh' d]dY']g' i' gYX' / d'fcdYf' m'g]h'YX' UbX' cZ' UX'Ye' U'h' \Y] [\h' h'c' d'f'c'j']X'Y' g']Z]V]Y'bh' X'f'U'z' i' 'b'gd'YV'h' h'Y' j' Ybh]b[' g'ng'h'a' Ub'bi' U' m'z'c'f' V'c'W]U[Y' UbX' g'] [b'g' cZ' XYH'f]c'fU'h]cb''

GENERAL

i' 'bgtU'U'h]cb' UbX' fYdU]f' g' l'ci' X' VY' X'cbY' V'm' U' ei' U]U'YX' g'Yf]]W' d'Yf'g'cb'' H'Y' Udd']UbW' g' l'ci' X' VY']b'gd'V]W'X' VY'z'c'f' h'Y' U'fgh' i' gY' UbX'z' Ub'bi' U' m' h'Y'f'U'z' h'f' V'm'U'ei' U]U'YX' g'Yf]]W' d'Yf'g'cb'' A' c'fY' Z'f'Ye' Ybh' V'W]Ub]b[' a' Um'VY' f'Ye']fYX' X'i' Y' h'c' Y']V'g'g]j' Y']b'h' Z'f'ca' V'W'f'd'Y'h]b[' z' VYXX]b[' a' U'h'f]U'z' Y' h'W' 'h']g']a' d'Y'f'U'h]j' Y' h'Y' V'z'bf'c'' V'z'a' d'U'f'ra' Y'bh'g'z' Vi' f'b'Y'f'g' UbX' V'f'W' U'h]b[' U]f' d'U'gg]U[Y'k' U'h'g' cZ' h'Y' Udd']UbW' VY' _Y'dh' V'W]Ub''

i' 8i' Y' h'c' \] [\ h'Y' a' d'Y'f'U'h' fY'g'z' h'Y' Udd']UbW' g' l'ci' X' VY' 'c'W]h'YX' c'i' h' cZ' \] [\ ' h'f'U'z]W'U'f'Y'U'g' UbX' U'k' Um' Z'f'ca' z' f'b]h' fY' UbX' X'f'U'd'Y'f]Y'g''

Children and adults should be alerted to the hazards of high surface temperatures and should stay away to avoid burns or clothing ignition.

Young children should be carefully supervised when they are in the same room as the appliance.

FOR YOUR SAFETY

i' 'bgtU'U'h]cb' UbX' g'Yf]]W' a' i' gh' VY' d'Y'f'Z'c'fa' YX' V'm' U' ei' U]U'YX']bgtU' Y'z' g'Yf]]W' U[Y'b'V'h'c'f' [Ug'g' d'd']Y''

i' H']g']bgtU'U'h]cb' a' i' gh' V'z' b'Z'c'fa' h'c' 'c'W' V'z'XY'g' c'f'z']b' h'Y' U'v'g'Y'b'W' cZ' 'c'W' V'z'XY'g'z' h'c' h'Y' W'f'f'Y'bh' 7.5B#7; 5! 6%(-)]bgtU'U'h]cb' V'z'XY' f'f'Ub'U'X'U'c'f' B'U'h]cb'U' : i' Y''; Ug' 7cXY' 5BG=N&&' "%&' f'] G5E''

i' H'c' d'f'Y' Ybh']b' 7' fr'z' X'c' b'ch' U'c'k' ' Ub'nc'b'Y' k' \c']g' i' bZ]a']U'f'k']h' h'Y' g'rc' Y' h'c' c'd'Y'f'U'h'Y']h''

WARNING: : U]i fY' h'c' d'cg]h]cb' h'Y' d'U'f'g']b' U'W'z'f'X'UbW' k]h' h'Y' X]U[f'Ua' g']b' h']g' V'cc' _Y'h'z'c'f' Z]U]i' fY' h'c' i' gY' c'b'm' d'U'f'g' g'd'V]U'W' m' U'd'd'f'c'j' YX' k]h' h']g' Udd']UbW' a' Um' fY'g' 'h']b' d'f'cdY'f'fm' XUa U] Y' c'f' d'Y'f'g'cb' U']b' 7' fr'z'

WARNING: 8c' b'ch' c'd'Y'f'U'h'Y' k]h' h'Y' ['U'gg' Z'f'c'bh' f'Y'a' c'j' YX'z' V'W]U'YX' c'f' V'f'c' _Y'b'' ' F'Y'd'U'W'a' Ybh' cZ' h'Y' ['U'gg' a' i' gh' VY' X'cbY' V'm' U']W' b'g'YX' c'f' ei' U]U'YX' g'Yf]]W' d'Y'f'g'cb''

i' B'Y' Yf' i' gY' g'c']X' z' Y'g' g']W' U'g' k' c'c'X'z' d'U'd'Y'f'z' V'W'f'X'c'U'f'X'z' V'z'U'z' c'f' Ub'm'U'Ua' a' U'VY']'ei']X'g'z' Y'h'V'z']b' h']g' Udd']UbW''

i' 8c' b'ch' i' gY' h']g' \Y'U'h'f']Z' Ub'm' d'U'f'h' \U'g' V'Y'Y'b' i' b'X'Y'f' k' U'h'Y'' 'a' a' YX]U'h' m'W'' U' ei' U]U'YX' g'Yf]]W' h'Y'W'b]V]Ub' h'c']b'gd'V]W'h' h'Y' \Y'U'h'f' UbX' h'c' f'Y'd'U'W' Ub'm' d'U'f'h' cZ' h'Y' V'z'bf'c'' c'f' [Ug' V'z'bf'c'' g'ng'h'a' g' h'U'h' \U'j' Y' V'Y'Y'b' i' b'X'Y'f' k' U'h'Y''

i' 8c' b'ch' U'm' gY' h'Y' ['U'gg' V'm'g'f]]b[']h'c'f' g'Ua' a']b[' h'Y' X'c'c'f' g'i' h''

HUV`Y`cZ`7`cbhYbhg

GUZYfm DFYWli h]cbg".....&
HUV`Y`cZ`7`cbhYbhg".....
7cXYg`5bX`5ddfcj Ug".....(
GdYV]UW]h]cbg".....)
8]a Ybg]cbg".....)
FUh]b[`@JY`@cW]h]cb".....)
CdYfU]b[`=bgfi W]cbg".....*
@[\h]b[`=bgfi W]cbg".....*
5X1 gh]b[`H\Y`JYbhi f]Yg".....+
Bcfa U`Gci bXg`8i f]b[`CdYfU]h]cb".....+
A U]bhYbUbW`UbX`GYfj]W".....,
CdYb]b[`H\Y`8ccf".....,
7`YUb]b[`H\Y`; `Ugg".....,
Hc`FYd`UW`8ccf".....,
7`YUb]b[`H\Y`=bg]XY`CZH\Y`;]fVcl ".....,
7`YUb]b[`D`UH\X`Gi fZ]Wg".....-
6`ck Yf`FYa cj U".....-
6`ck Yf`FYa cj U".....-
: i Y`7cbj Yfg]cb".....%\$
=b]h]U`=bgU`U]h]cb".....%&
DFydUfU]h]cb`; cf`=bgU`U]h]cb".....%&
7`YUfUbWg]hc`7ca Vi gh]VYg".....%&
: `i Y`; Ug`Gd]`Gk]hW".....%&
JYbh]b[".....%
A Ubi Z]W] fYfg]; YbYfU`JYbh]b[`; i]XY]bYg".....%
; YbYfU`JYbh]b[`: cf`H\Y`9, & ".....%
HYfa]bU]h]cb".....%
=bgU`U]h]cb`; =bhc`5b`9l]gh]b[`7`\ja bYm".....%
GfU][\h]JYfh]W`=bgU`U]h]cb".....%
9`YVf]W`FYe]]fYa Ybhg".....%*
; Ug`@]bY`7cbbYV]cb`UbX`HYgh]b[".....%+
GYWzbXUfm`=bgU`U]h]cb".....%
=bgU`U]h]cb`; cZ`@c[`GYhUbX`9a VYfg".....%
Hfci VY`G\cch]b[".....&\$
DUfng`@]gh".....%&
DUfng`8]U[fUa `!`7\Ugg]g".....&
DUfng`8]U[fUa `!`; Ug`HFUm/`8ccf".....&(
K UffU]bhm".....&)
=bgU`U]h]cb`; 8UHU`G\YYh".....&

7 cXYg 5bX 5ddf cj U` g

BV: H\jg JYbhYX Udd]UbW Xfuk g U`cZ]hg Vta Vi gh]cb U]f Zfca H\Y Xk Y`]b[U`bX`a i ghVY j YbhYX i g]b[]ghYX 6`cf @j Ybh`A UmUgc VY j YbhYX h`fci [\ U`Vtbj Ybh]cbU`W]a bYmi g]b[U`W]a bYm]bYf`_]h`

H\jg Udd]UbW` \Ug VYYb hYghYX` UbX` Uddfcj YX` Zcf`]bghU`Uh]cbg` Zfca` \$`ZYHh`c`&\$\$\$`f`%\$`a`E`Uvcj Y`gYU` Yj Y`"

In the USA: H\Y` Udd]UbW` a UmVY`]bghU`YX` Uh` \][\Yf` U]h]i XYg` D`YUgY` fYZf` hc` nci` f`5a` Yf]W]b` ; Ug` 5ggcV]U]cb [i]XY]bYg`k \]W` g]U]hY` . h`Y` gYU` Yj Y` fUHYX`]bdi` h`cZ` ; Ug` 8Yg] [bYX` 5dd]UbWg`]bghU`YX` Uh` Y`Yj` Uh]cbg` Uvcj Y`&\$\$\$`f`%\$`a`E`ZYHh]g]h`c` VY` fYXi` WX` (i` Zcf` YUW` %\$\$\$`ZYHh`f` \$)` a`E`Uvcj Y`gYU` Yj Y`" fYZf` Ugc` hc` cW` U`i` h`cf]h]Yg` cf` VtXYg` k \]W` \Uj Y` f]gX]W]cb`]b` nci` f` UfYU` fY [UfX]b [H\Y` XY! fUHY` [i]XY]bYg`

In Canada: K \Yb` h`Y` Udd]UbW`]g`]bghU`YX` Uh`Y`Yj` Uh]cbg` Uvcj Y` () \$ \$`ZYHh`f`%` +&`a`E`Z`h`Y` Wf]U]YX` \][\ U]h]i XY` fU]b [g]U` VY` fYXi` WX` Uh`h`Y` fUHY` cZ` (i` Zcf` YUW` UXX]h]cbU` %\$\$\$`ZYHh`f` \$)` a`E`

j` H\jg Udd]UbW` \Ug VYYb hYghYX` Vm=BH9FH9?` f**Warnock Hersey** E`UbX` Zci` bX` hc` Vta` d`mk`]h` h`Y` Yg]U`]g]YX` J`9BH98` ; 5G` :` =F`9D@579` <`95H9F` g]U]bXUfXg`]b` 75B585` UbX` h`Y` I` G5` Ug` Zc` ck` g`

VENTED GAS FIREPLACE HEATER (EG28 BV NG/LPG)

H9GH98` HC` 5BG=N&%, , U!&\$\$` #7G5` &""` U!&\$\$` J`9BH98` ; 5G` :` =F`9D@579` <`95H9F` G` 75B#7; 5`&`%`+!A`-%; 5G` :` =F`98` 5DD@5B79G` :` CF` <`= ` <`5@H`HI` 89G` 7G5` D` (%\$`&`H9GH`B; `A`9H`<`C8` :` CF` A`95GI` F`=B; `5BBI` 5@` :` =F`9D@579` 9` :` =7`=9B7M`

This ENVIRO EG28 BV Fireplace:

j` <`Ug` VYYb` Wf]U]YX` Zcf` i` gY` k`]h` Y]h` Yf` bU]i` fU` cf` dfcdUbY` [UgYg` fGYY` fU]b [U`WY` E` j` =g` bchZcf` i` gY` k`]h` gc`]X` Z` Y`g` j` =g` Uddfcj` YX` Zcf` VYXfcca` cf` VYX` g]h]b [fcca` " **IN CANADA.** a` i` ghVY`]bghU`YX` k`]h` U`]ghYX` k` U` h`Yfa` cghU` **IN USA.** gYY` WffYbh` 5BG=N&&` "%`Zcf`]bghU`Uh]cb`]bghU` W]cbg` E` j` A` i` ghVY`]bghU`YX`]b` U`Wf]U]bW` k`]h` cW` VtXYg` =Z` bcbY` YI`]g]i` gY` WffYbh`]bghU`Uh]cb` VtXY` 75B#7; 5` 6%` (-`]b` 7UbUXU` cf` 5BG=N&&` "%`B: D5`) (`]b` h`Y` I` G5`" j` A` i` ghVY` dfcdYf` m]VtbbYV]W]X` hc` Ub` Uddfcj` YX` j` Ybh]b [g]ghY`a` UbX` bchVtbbYV]W]X` hc` U`W]a` bYmi` U`i` Y` gYfj`]b [U` gYdUfUHY` gc`]X] Z` Y` Vi` fb]b [Udd]UbW`" j` 5fY` Uddfcj` YX` Zcf`]bghU`Uh]cb` cb` Vta` Vi` gh]VY` a` U]Yf]Ug` f]Y`" K` ccXz` WfdYh` cf`]bc` Yi` a` E`" j` =g` bchUddfcj` YX` Zcf` Wcgyhcf` fYWggYX`]bghU`Uh]cbg`

IMPORTANT NOTICE (Regarding first fire up):

K \Yb` h`Y` i` b]h`]g` h`i` fbYX` cb` Zcf` h`Y` Ufgh]h`a` Yz`]h` g]ci` X` VY` h`i` fbYX` cb` hc` \][\` k`]h`ci` h`h`Y` Z]b` cb` Zcf` h`Y` Ufgh] (` \ci` fg`) H\jg` k`]` W` fY` h`Y` dU]b]h` z` c` g] [Ug` Y` h`a` U]Yf]U` UbX` ch` Yf` dfcXi` V]g` i` gYX`]b` h`Y` a` Ubi` Z]M] f]b [dfcWgg` =h]g` U]Xj`]gU]VY` hc` cdYb` U` k`]bXck` cf` Xccfz` Ug` h`Y` i` b]h`k`]` g]Uf]h`c` ga` c` _` Y` UbX` W]b`]f]h`UHY` gca` Y` dYcd` Y`" 5ZYf` h`Y` i` b]h` \Ug` [cbY` h`fci [\` h`Y` Ufgh]Vi` fb` h`i` fb` h`Y` i` b]h`cZ]]bW` X]b [h`Y` d] chz` Yh` h`Y` i` b]h [Yh` Vt` X` h`Y` b` fYa` cj` Y` h`Y` [Ugg` Xccf` UbX` W]Ub`]h`k`]h` U` [ccX` [Ug` UfYd` U]W` [Ugg` W]UbYfz` Uj` U]U]VY` U]h`nci` f` cW` 9BJ` =F` C` XYUY`"



G dYW]Z]WU]h]c b g

8-A 9BG-CBG.

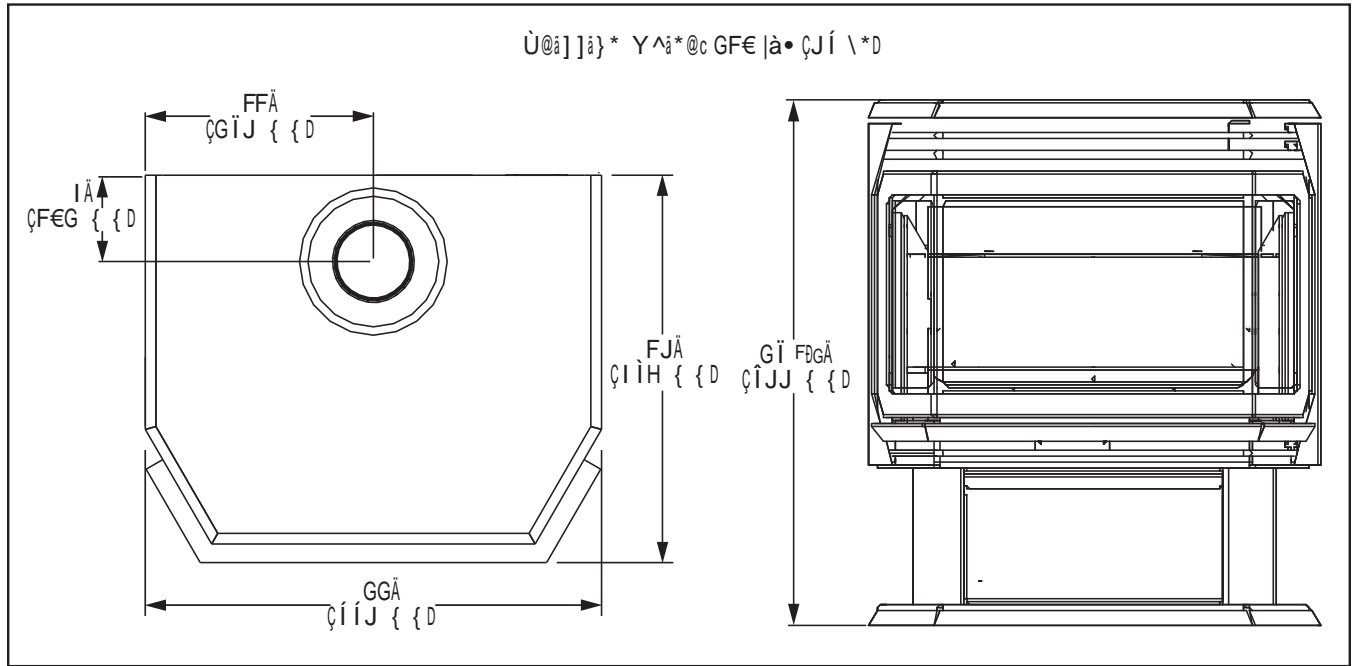

Figure 1: EG28 Exterior Dimensions.

F 5HB; @569@C75H-CB.

H\Y'fU]h]b[``UVY'']g'Zci bX'']bg]XY'h\Y'f][\h'WV]bYh]g]XY'dUbY''

C dYf Uh]b [' =bghf i Wh]c bg

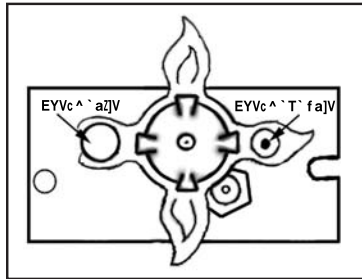

Figure 3: Pilot Burning.

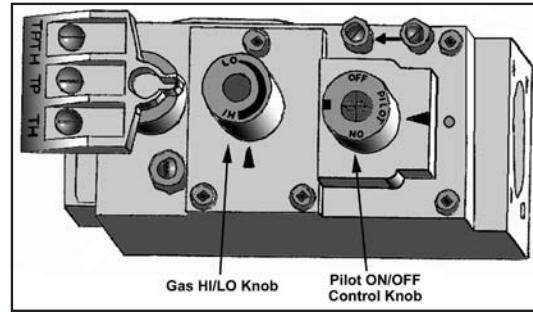

Figure 4: Gas Valve.

58> GH-B; 'H-9'J 9BH F=9G.

- ## FYa cj Y'hAY Ug\ g'LYZVmi bXc]b['hAY'gWYk 'UhYUW'YbXZ'di "'g'LYZ'rc k UFXg'nci "
- ## FYa cj Y'cbY'gWYk 'Zca 'hAY'VZj Yf'd'UH'c'VUHYX'VY'ck 'hAY'Ug\ g'LYZ'@ccgYb'hAY'ch'Yf'gWYk 'fXc'bch' fYa cj YE'gk]b['hAY'VZj Yf'd'UH'ci hcZ'hAY'k UmUbx'h[\hYb'gWYk 'Xck b'hc '\c'X'h]b'd'UW"
- ## K]h'Ucb['gWYk Xf]j Yf'fchUH'gdf]b['W]dg'hc'cdYb'cf'VZgy'hAY'g'li hYf'hc'hAY'XYgj'fYX'gYH]b["

HAY'j Ybhi f]Yg'U'ck g'hAY'Ua ci bhczU]f'VZa]b[']bhc'hAY'Ufyd'UW' hc'VY'UX'g'YX']b[cfXYf'hc'UWVZa a cXUH'X]ZZYfYbhi W]a UHYg'Ubx' j Ybh]b['UffU]b[Ya Ybhg' GHUfhi'hAY'd]chiUbx'hAY'b'hAY'Vi fbYf'A U_Y' g'fY'hAY'd]chiU]a Y']g'Vi fb]b['bcfa U'mUbx'bcby'cZ'hAY'Vi fbYf' dcfhg' UfY' d'i [[YX"' @h'hAY' Ufyd'UW' Vi fb' Zcf' fci [\m'UZYb' a]bi hYg'Ubx'hAY'b'YI Ua]bY'hAY'U]a YgZ'VZa dUfY'hAY'U]a Yg'hc' :]i fY'&*"

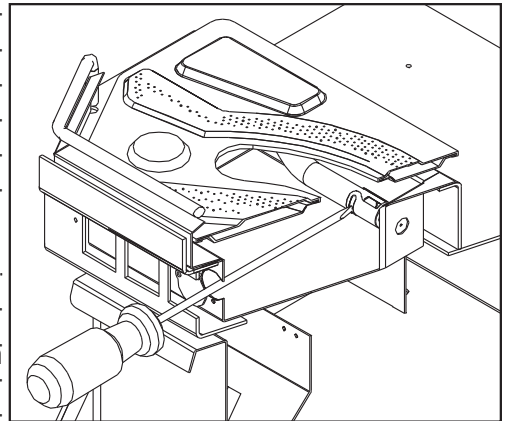

Figure 5: Venturi Adjustment.

HAY'XYU'U]a Y'k]'VY'Vi Y'Uh'hAY'VUgy'Ubx'] [\h'cfU]b[Y'UWcj Y'' HAY'U]a Yg'g'ci 'X'VY'cZ'a YX]i a '\Y][\H' =Z'hAY'U]a Yg'cc_']Y' h']gZ'bc'j Ybhi f]UX'g'ra Ybh]g'bYYXYX"' =Z'hAY'U]a Yg'UfY'ZU]f'mig\cfh' Ubx'a cghm'Vi YZ'hAY'Ufyd'UW']g[YH]b['hc'a i W'U]f' HAY'fY'ZcfYZ' hAY'j Ybhi f]Yg'g'ci 'X'VY'VZgyX'g][\h'mi bh] hAY'VZffYV]U]a Yg'UfY' UW'Y]YX"' : 'Ua Yg'hAY'U]a UfY'j Yf'mcfU]b[YZ'k]h' HU'Z'XUF'Z'g'f]b[m' h]dgZ'UfY'bch[YH]b['Ybci [\U]f' CdYb'hAY'j Ybhi f]i bh] hAY'U]a Yg'WU]b'i d"' =Z'hAY'j Ybhi f]]g'cdYbYXZ'cf' VZgyX'U' hAY'k UnZ'Ubx'hAY'VZffYV]U]a Yg'WU]b'ch'VY'U]h]b]YXZ'hi fb'cZ'hAY' [Ug'Ubx'VZ'bhU]m'hAY'XYUYf'

Warning: =bVZffYV]j Ybhi f]UX'g'ra Ybh'a Um'YUX'hc']a d'fcdYf' VZa Vi g'h]cbZ'k \]W']g'U'gUZYhm' \UhUfX"' 7cb'U]m'hAY'XYUYf']Z hAY'f]]g'U]b'm'VZ'bWfb'U]ci h'hAY'j Ybhi f]UX'g'ra Ybh'

Table 1: Venturi Setting

	B;	@D
JYbhi f]GYH]b[%#%Î'a]b"	Î'a]b"

BCFA 5@Gci B8G'8i F=B; 'CD9F 5H=CB.

Table 2: Normal Sounds

Component	Sound & Reason
9; &	7fYU_]b['k \Yb \YU]b['i d'cf'VZc']b['Xck b"
6i fbYf	@[\hidcd'cf'dccZk \Yb'hi fbYX'cZZ'h']g']g'a cfY'VZa a cb'k]h' @d'i b]hg'
HYa dYfUhi fY'GYbgcf	7]b_]b['k \Yb]hgYbgYg'hc'hi fb'hAY'V'ck Yf'cb'cf'cZ'
D]ch: 'Ua Y	E i]Yhk \]gdYf'k \]Y'hAY'd]chiU]a Y']b'cb"
6'ck Yf'#: Ub	5]f'a cj Ya Ybhi'hAY'U]b'WYUgY'Ubx'XYWYUgYg'k]h'hAY'gdYX'cZ'hAY'V'ck Yf'hAY' V'ck Yf']g'di g]b['hAY'\YU]h'Zca 'hAY'Ufyd'UW']bhc'hAY'fcca "
; Ug'7cb'f'c']U] Y	8i ~W]W'k \Yb'hi fb]b['cb'cf'cZ'h']g']g'hAY'j U] Y'cdYb]b['Ubx'VZc]b["

A U]b hYb Ub W' Ub X ' G Yf j]W'

DYf]cX]W'mWYV'rc'Ybgi fy'hUhmci f'X]fYVmj YbhgnghYa 'jg'WU'ub"

DYf]cX]W'mWYV'rc'Ybgi fy'hUhmci f'X]fYVmj YbhgnghYa 'jg'WU'ub" 7\YW'rc'gY'hUhmci f'X]fYVmj YbhgnghYa 'jg'WU'ub" 7\YW'rc'gY'hUhmci f'X]fYVmj YbhgnghYa 'jg'WU'ub"

CD9B-B; Hk9'8CCF.

H fb'i b]hcZZUbX'k U]hi bh] 'hY'Udd']UbW' \Ug'Vt'c'YX'Xck b"
%''CdYb'hY'f] [\h\UbX'\]b[YX'g]XY'Udd'z'k \]W'k]''Yi d'cgY'U'Xccf'
ZUghYbYf''i g]b['U' 'I'k fybVWZ'ccgYb'hY'ZUghYbYf'
&''8i Y'rc'hY'g'UdY'cZ'hY'VUmik]bXck 'Xccf''Mti 'a i ghU'gc'cdYb'
hY'YZh\UbX'g]XY'Udd'VYZcfY'UthYa dh]b['rc'cdYb'hY'Xccf''
' ''=Z'hY'Xccf'a i ghVY'fYa cj YX'cdYb'hY'Xccf'UbX'']Zi'hY'Xccf'
d]bg'ci hcZ'hY'\]b[Yg'f]gY'U[i fY '*L'
('' '9bgi fy'hY'Xccf']g' d'fcdYf'm ZUghYbYX' UZhf' WU'ub]b['VYZcfY'
UthYa dh]b['rc'fy!] [\h'hY'Udd']UbW'

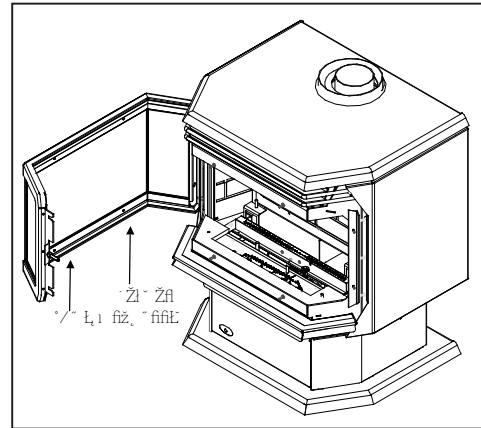

Figure 6: Removing the Door.

7@95B-B; Hk9'; @5GG.

Allow the glass to cool before cleaning. -hik]''VY'bYWggUfmihc'WU'ub'hY'WfUa]W['Ugg'dYf]cX]W'm'
8i f]b['U'Vt'X'gUfhi d'z'Vt'X'YbgU]cb'k]''gca Y'h]a Yg'Zcfa 'cb'hY' ['Ugg''H']g']g' U'bcfa U'Vt'X'gU]cb'k]h'
U'' [U'g'UfYd'UW'g'UbX'g'rc'j Yg''<ck Y] Yfz'h']g' Vt'X'YbgU]cb'WU'ub'U'ck 'Xi gh'UbX'']bh'rc'W]b['rc'hY' ['Ugg'
g' fZUW''=b]h]U'dU]bhW'f]b['cZ'hY'Udd']UbW'WU'ub'YUj'Y'VY\]bX'U'g][\h'U'a 'cb'hY' ['Ugg''H']g']g'U'thYa d'cfUfmi
d'f'cV'Ya ''=h]g'h'YfYz'cfY'fYVt'a a YbXYX'h'U'h'Y' ['Ugg'VY'WU'ubYX'']b]h]U'mUZhf'UVci h'hY'UfghZci f'\ci f'cZ
i gY''8YdYbX]b['i d'cb'hY'Ua ci bh'cZi gYz'WU'ub]b['g]ci 'X'VY'fYei]fYX'bc'a cfY'h'U'ub'h'c'cf'h'fY'Y'h]a Yg'
dYf'gYUgcb''Hc'WU'ub'hY'Xccf'z' gY'U'a]X ['Ugg'WU'ubYf'UbX'U'gcZi'Vt'h'cf'U ['Ugg'WU'ubYf'Uj'U]UVY'Zca'
mci f'9bj]f'c'XYUYf''5VfUg]j'Y'WU'ubYfg'k]''XUa U[Y'hY' ['Ugg'

Hc'F 9D@579'8CCF.

H'Y' ['Ugg']b'h']g'Udd']UbW']g'Ub']bhY[fU'dUfhi'cZ'hY'Xccf'UggYa V'mi '=Z'hY' ['Ugg']g'XUa U[YX'cf'Vfc_Yb'U'
fYd'UW'a Ybh]bYf'Xccf'k]h' ['Ugg'UggYa V'mia i ghVY'di fWUgYX'

H'Y' ['Ugg']b'h']g'Udd']UbW']g'WfUa]W' '=Z'hY' ['Ugg']g'XUa U[YX'cf'Vfc_Yb'U' ZUf'c'f'mi'Xccf'k]h' ['Ugg'
fYd'UW'a Ybhia i ghVY'i gYX'

FYa cj Y'hY'Xccf'k]h' ['Ugg'U'byk 'Xccf'UggYa V'mia i ghVY'di fWUgYX'Zca 'Ub'9BJ =FC'XYUYf'f'dUfhi' . .
9; & !%\$ 'L' **Do not use a substitute materials; it will void the warranty.**

7@95B-B; Hk9'=BG-89'C; Hk9'; =96CL.

%''H fb'cZ'hY'i b]h]UbX'U'ck]h'rc'Vt'c'Xck b'Vt'a d'YH'n'
&''FYa cj Y'hY'c[g'WU'fYz' ''m'Zca 'hY'UfYVcl''; Ybhmi'fYa cj Y'hY'Ya VYfg'UbX'd'UW'cb'U'd]YW'cZ'dUdYf'
h'ck Yz'i bh]f'YU'Xm'rc'fYd'UW'
' ''JUW'i a 'hY'Vt'rc'a 'cZ'hY'UfYVcl' h'c'fci [\n'i 7UfYz' ''m'WU'ub'cZ'Ubmi'Xi gh'cb'hY'c[g'UbX'fYa cj Y'Ubmi'
']bh'Zca 'hY'a U]b'Vi fbYf'UbX'd]ch'Vi fbYf'
('' '5Zhf'WU'fYz' ''m'fYd'UW]b['hY'c['UbX'Ya VYfg']b'hY'f' Vt'fYVmi d'cg]h]cbg'f]gY' G97CB85FM =BGH5@5H-CB' !'
=BGH5@5H-CB' C: '@; 'G9H'5B8'9A'69GtZ' UbX'hY'Xccf'\Ug'VYyb'fYgYUYXz'fy!][\h'hY'd]ch'Z'Z'ck]b['hY'
']bg'f'i W]cbg'cb'hY''] [\h]b['UVY'U'f'WU'ubYX'rc'hY'i b]h'

A U]b hYb Ub WY · 5 b X · G Y f j]WY

: I 9@7CBJ 9G-CB.

HC '69' -B GH5@@98 '6M5'E I 5@- 98'G9F J =7 9'5; 9B 7 MCB @M

Please read and understand these instructions before installing.

Warning: This conversion kit shall be installed by a qualified service agency in accordance with the manufacturer's instructions and all applicable codes and requirements of the authority having jurisdiction. If the information in these instructions is not followed exactly, a fire, explosion or production of carbon monoxide may result causing property damage, personal injury or loss of life. The qualified service agency is responsible for the proper installation of this kit. The installation is not proper or complete until the operation of the converted appliance is checked as specified in the manufacturer's instructions supplied with the kit.

Kit Parts List:

- %! 'Cf]UW'fB; '!' ('8AG'cf'@!'') '8AGL
- %! 'D]ch' -b'YVtcf'fB; ''\$''&'a a /'@' '\$'') 'a a t
- %! ' -bgtU'U]hcb']bgrfi W]cb'g\YYh
- %! '7cbj Yfgjcb'UVY'

7UFYZ ''m]bgdYVtU' ''dUfhg' g' dd'YX' k]h' h']g' Vt'bj Yfgjcb' _]h' =Z Ubm'dUfhg' \Uj Y' VYyb' XUa U[YX' cf' UfY' a]gg]b[ž Vt'bhU]m' mci f' XYU'Yž' X]grf]Vi h'cf'cf' Vt'i f]Yf' Vt'a dUbm'hc' \Uj Y' h'Ya' 'fyd'UWX' VYZ'cf' g'Ufh]b['h']g']bgtU'U]hcb''

Conversion Kit Installation:

%' H' fb' Vt'bf'c' _bcV'cb' h'Y' [Ugg' Uj Y' h'c' h'Y' [C: : I' d'cg]h'cb' UbX' g'vi h' h'Y' [Ugg' g' dd' m'cZZ' Uh' h'Y' g'vi H'cZZ' j' Uj Y' i' dg'f'YUa' 'cZ' h'Y' i' b]h' '75I' H-CB. 'h'Y' [Ugg' g' dd' m'a' i' gh' VY' g'vi h'cZZ' d'f]cf' h'c' X]g'Vt'bb'YV]b['h'Y' Y'YV]f]WU' d'ck' Yf' UbX' VYZ'cf' d'fc'WYX]b['k']h' h'Y' Vt'bj Yfgjcb' '5'ck' h'Y' j' Uj Y' UbX' i' b]h' h'c' Vt'c' X'ck' b' h'c' f'cca' 'h'Ya' d'Yf'U' h' f'Y''

&' FYa' cj Y' h'Y' ['Ugg' Uj Y' g' l'ck' b']b' h'Y' A 5-BH9B5B79'5B8' G9FJ =79' !' C'D9B-B; 'H'k'9'8CCF''

' '' 7UFYZ ''m]f'Ya' cj Y' h'Y' 'c['g'Yh'UbX' Ya' VYf' a' U]Yf]U']Z' h'Y'm'UfY']bgtU' YX''

(' '' FYa' cj Y' h'Y' Vi' fb'Yf' Uj Y' g' l'ck' b']b' h'Y' A 5-BH9B5B79'5B8' G9FJ =79' !' '6I' FB9F' F'9A' CJ5@''

)'' 7cbj Yfh' h'Y' Vi' fb'Yf' cf]UW'f]g'.

U' FYa' cj Y' h'Y' a' U]b' Vi' fb'Yf' cf]UW' k']h' U' ']b'W' X'Y'Y' d' g'c'W'Y' h'

Vt' Di' h' U' VYUX' cZ' d]d'Y' h' f'YUX' g'Y' U'Ub' h' c'f' U' d' d'f'c' YX' H'Y' U'cb' h'U' d'Y' cb' h'Y' cf]UW' h' f'YUX' g' VYZ'cf']bgtU']b[']b' h'c' h'Y' V'f'Ugg' Y' V'ck''

Vt' -bgtU' h'Y' b'Yk' cf]UW' f]g' Z'f'ca' h'Y' _]h']b' h'c' h'Y' V'f'Ugg' Y' V'ck''

*'' 7cbj Yfh' h'Y' d]ch']b' YVt'cf'.

U' Di' '' h'Y' d]ch' \ccX' g'f]U] [\h' i' d' h'c' U'W'V'g' h'Y' d]ch']b' YVt'cf''

Vt' I' g]b['U') # &' cf' ('a' a' '5' Yb' _Ynā' f'Ya' cj Y' h'Y' d]ch']b' YVt'cf''

Vt' -bgtU' h'Y' b'Yk' d]ch']b' YVt'cf' g' dd'YX' k']h' h']g' Vt'bj Yfgjcb' _]h' 'G'ja' d' m'g'V'Y'k' h'Y' b'Yk']b' YVt'cf']bgtU' h'Y' d]ch' \ccX' i' g]b['h'Y' '5' Yb' _Ynā'

Xt' F'Y]bgtU' h'Y' \ccX' V'm' d' U]b['h'Y' \ccX' cb' h'Y' Ugg' Ya' Vnā']b' Y' i' d' h'Y' _Ym' k' U'nā' UbX' g' b'U' d]b' h'c' d' U'W''

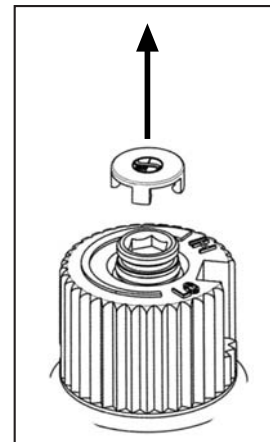

Figure 9: Removing valve cap.

A U]b hYb Ub W' 5 b X ' G Y f j] WY

+'' 7cbj Yfh hY' G+H' [Ug j Uj Y.

U' FYa cj Y hY' V' UW' dfch V' W' d' Z' ca' hY' < # @ C' _bcV Vm' \ UbX' g' c' k b'] b' :] [i fY' - "

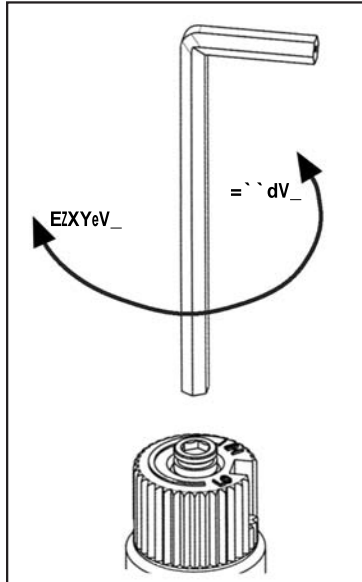

Figure 10: Removing valve screw.

V' E' =bgYfh U') # & i' cf' (' a a ' 5'' Yb' k fYbW'] b' c' hY' \ YI U' [cbU' _Ym' k UmicZ hY' g' W' Yk' f' g' Y' Y' :] [i fY' % \$ E' z' fchU' Y'] h' V' e' i' bhY' f' V' c' W' k'] g' Y' i' bh']' h' i'] g' Z' F' Y' Y' UbX' YI f' U' V' h'] h'

V' E' 7' \ Y' W' h' U' h' hY' g' W' Yk'] g' W' Y' U' b' UbX'] Z' b' Y' W' g' g' U' f' m' f' Y' a' c' j' Y' X'] f' h'

X' E' : '] d' hY' g' W' Yk' f' F' Y' Z' f' h' c' :] [i fY' % \$ E'

Y' E' i' g'] b' [' hY' 5'' Yb' k fYbW' U' g' g' c' k' b'] b' :] [i fY' % \$ Z' fchU' Y' hY' g' W' Yk' V' c' W' k'] g' Y' i' bh'] U' h' c' f' e' i' Y' c' Z' -] b' W' ' V' g' " **WARNING!** 8' c' b' c' h' i' c' j' Y' f' h'] \ hY' b' hY' g' W' Yk' " - h'] g' f' Y' V' e' a' a' Y' b' X' Y' X' h' U' h' n' e' i' ' [] d' hY' k' fYbW' V' m' hY' g' c' f' h' i' g'] X' Y' "

Z' E' J' Y' f'] z' m' h' U' h'] z' hY' V' e' b' j' Y' f' g'] c' b'] g' Z' f' c' a' ' B' ; ' h' c' @; z' hY' g' W' Yk' ' a' i' g' h' V' Y' f' Y' ! U' g' g' Y' a' V' Y' X' ' k'] h' hY' f' Y' X' ' c' ! f'] b' [] g'] V' Y' f' F' Y' Z' f' h' c' :] [i fY' % \$ E' - z' hY' V' e' b' j' Y' f' g'] c' b'] g' Z' f' c' a' ' @; ' h' c' B; z' hY' f' Y' X' ' c' ! f'] b' [' c' Z' hY' g' W' Yk' ' a' i' g' h' V' Y' b' c' h' i' g'] g'] Y' Y' "

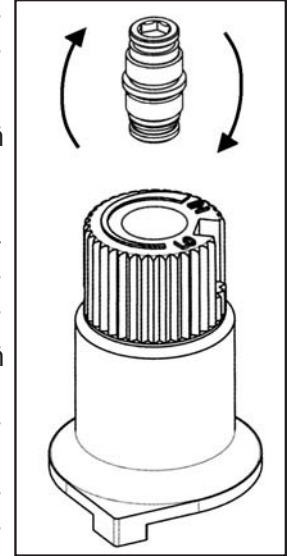

Figure 11: Flip valve screw.

[E' F' Y' ! U' h' U' W' ' hY' V' U' W' ' d' f' c' h' V' W' ' c' b' ' W' d' ' h' U' h' k' U' g' f' Y' a' c' j' Y' X' '] b' g' h' d' ' U' f' i'] [i fY' - E' "

, '' F' Y'] b' g' U' ' ' hY' V' i' f' b' Y' f' z' ' V' f'] W' ' d' U' b' Y' g' z' ' c' [' g' Y' h' z' ' Y' a' V' Y' f' g' z' ' U' b' X' ' [' U' g' g' ' X' c' c' f' ' 5' ' g' c' ' f' Y' Z' Y' f' ' h' c' ' G' 9' 7' C' B' 8' 5' F' M' = B' G' H' 5' @ 5' H' - C' B' ' ! ' = B' G' H' 5' @ 5' B' ; ' @ ; ' G' 9' H' 5' B' 8' 9' A' 6' 9' F' G' " ' K' \ Y' b' f' Y' !] b' g' U' '] b' [' hY' V' i' f' b' Y' f' z' ' Y' b' g' i' f' Y' ' h' U' h' hY' ' d'] c' h' i' \ c' c' X' '] b' '] b' '] b' Y' ' k'] h' hY' g' a' U' ' \ c' Y' U' h' hY' Y' X' [Y' c' Z' Z' c' b' h' i' U' b' X' f' Y' U' f' V' i' f' b' Y' f' ' C' b' ' g' c' a' Y' i' b'] h' g' i' n' e' i' ' k'] ' b' Y' Y' X' ' h' c' ' d' U' m' g' d' Y' W'] U' ' h' Y' b' h' i' c' b' ' k' \ Y' b'] b' g' U' '] b' [' hY' V' i' f' b' Y' f' ' h' U' h' hY' ' j' Y' b' h' i' f'] U' X' 1' g' h' a' Y' b' h' f' c' X' '] g' d' f' c' d' Y' f' m'] b' g' U' ' Y' X' '] b' c' h' hY' ' j' Y' b' h' i' f'] U' X' 1' g' h' a' Y' b' h' i' d'] Y' W' ' k' Y' X' Y' X' ' h' c' ' hY' V' i' f' b' Y' f' j' Y' b' h' i' f'] h' V' Y'

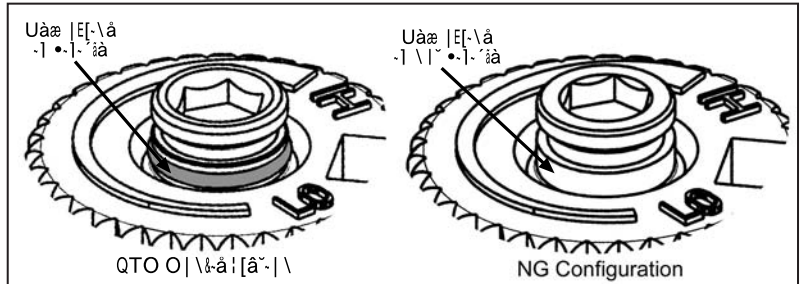

Figure 12: O-ring on valve screw.

- '' F' Y' V' e' b' b' Y' W' h' Y' a' U'] b' [' U' g' '] b' Y'] Z'] h' k' U' g' X'] g' V' e' b' b' Y' W' X' U' b' X' ' c' d' Y' b' hY' g' i' h' c' Z' z'] U' j' Y' U' h' hY' [' U' g' '] b' Y' ' h' c' ' hY' ' i' b'] h'

% \$'' I' g' Y' U' g' a' U' ' V' f' i' g' ' h' c' ' U' d' d' ' m' i' U' ' k' U' f' a' ' g' c' U' d' m' k' U' h' Y' f' ' g' c' i' h'] c' b' ' h' c' ' U' ' [' U' g' V' e' b' b' Y' W'] c' b' g' f' i' g' Y' U' \ U' Z' X'] g' ' g' c' U' d' ' U' b' X' \ U' Z' k' U' f' a' ' k' U' h' Y' f' e' " = z' U' [' U' g' ' Y' U' _'] g' d' f' Y' g' Y' b' h' z' ' V' i' V' V'] b' [' k'] ' c' W' W' f' " ; ' U' g' ' Y' U' _' g' W' U' b' ' V' Y' ' f' Y' d' U'] f' Y' X' ' V' m' i' g'] b' [' U' b' ' U' d' d' f' c' j' Y' X' ' d'] d' Y' ' h' f' Y' U' X' ' g' Y' U' U' b' h' c' f' ' U' d' d' f' c' j' Y' X' ' h' Y' U' c' b' ' h' U' d' Y' " ' B' 9' J' 9' F' ' I' G' 9' 5' B' ' C' D' 9' B' ; ' @ 5' A' 9' K' < 9' B' ' H' 9' G' H' - B' ; ' : ' C' F' @ 9' 5' ? ' G' "

% &' F' Y' V' e' b' b' Y' W' h' Y' Y' V' W' f'] W' ' d' c' k' Y' f' h' c' ' hY' ' i' b'] h'

% &' F' Y'] [\ h' hY' ' a' U'] b' ' V' i' f' b' Y' f' '] b' ' V' c' h' ' hY' ' [< =] ' U' b' X' ' [@ C'] ' d' c' g'] h' c' b' g' ' h' c' ' j' Y' f'] z' m' d' f' c' d' Y' f' ' V' i' f' b' Y' f' '] [b'] h' c' b' ' U' b' X' ' c' d' Y' f' U' h' i' c' b' ' U' b' X' ' d' f' c' d' Y' f' ' U' U' a' Y' ' U' d' d' Y' U' f' U' b' W' " ' 5' ' g' c' ' f' Y' Z' Y' f' ' h' c' ' G' 9' 7' C' B' 8' 5' F' M' = B' G' H' 5' @ 5' H' - C' B' ' ! ' @ ; ' G' 9' H' 5' B' 8' 9' A' 6' 9' F' G' = B' G' H' 5' @ 5' H' - C' B' ' Z' c' f' U' Z' U' a' Y' ' U' d' d' Y' U' f' U' b' W' ' d'] W' i' f' Y' "

% '' A' 5' ?' 9' G' I' F' 9' ' h' U' h' hY' V' e' b' j' Y' f' g'] c' b' ' U' W' Y' '] g'] b' g' U' ' Y' X' ' c' b' ' c' f' ' W' c' g' Y' ' h' c' ' hY' ' f' U' h'] b' [' ' U' W' Y' ' h' c' ' g'] [b'] z' m' h' U' h' hY' ' i' b'] h' \ U' g' ' V' Y' Y' b' ' V' e' b' j' Y' f' h' Y' X' ' h' c' ' U' X'] Z' Y' f' Y' b' h' z' ' Y' ' h' m' d' Y' "

≡b]h]U` `≡bghU` `Uh]c b

E I 5@≡ ≡98 `B GH5@@9F G `C B @M

WARNING:

CdYfUh]cb`cZ h.]g\YUHf`k \Yb`bchVtbbYVWX`hc`U`dfcdYf m]bghU`YX`UbX`a U]bhU]bYX`j Ybh]b[`gnghYa `Wlb`fYg]`h]b`WVfVcb`a cbcl]XY`f7Ct`dc]gcb]b[`UbX`dcgg]V`Y`XYUH`"

DF 9D5F 5H-CB `: CF `≡BGH5@@5H-CB.

j` FYa`cj`Y`h`Y`dUW]U[]b[`Zfca` `h`Y`Udd`]UbWz`UbX`WYVW`hc`a`U`Y`gi`fY`h`YfY`]g]bc`XUa`U[`Y`"≡Z XUa`U[`Y`]g`Zci`bXz`d`YUgY`fYdcfh]h]hc`Vch`h`Y`WVff]Yf`UbX`nci`f`XYUYf`Ug`gccb`Ug`dcgg]V`Y`"

j` 6YzcfY`VY[]bb]b[`z`WVfZ` `m`WYVW`h`Y`[`Ugg`Xccf`UbX`h`Y`"c[`gYh`

j` @WVhY`U`dcg]h]cb`k \YfY`h`Y`Ui`Y`gnghYa`cZ`h`Y`g]c]Y`Wlb`VY`dfcdYf m]bghU`YX`k]h]ci`h`XUa`U[]b[`h`Y`]bhY[]f]h]mcZ`h`Y`Vi`]X]b[/`Y"["W]h]b[`U`k`U`"cf`W"]b[`c]g]h`

j` 7\YVW`g]c]Y`Y`UbX`Ui`Y`gnghYa`WVUfUbW`fYei`]fYa`Ybh]g`"

j` @WVhY`h`Y`g]c]Y`k \YfY`]h]Wlb`VY`UWVggYX`VmU[`Ug]gi`dd`m`]bY`"

j` @WVhY`h`Y`g]c]Y`]b`U`Uf[`Y`UbX`cdYb`fcca` `h`Uh]g]WbhfU`m`c`WVhYX`]b`h`Y`\ci`gY`"H`g]k`]`cd]h]a`]nY`YUhi`V]VW`Uh]cb`UbX`Vt`a`Zc`f`h`

j` 5g`h`Y`g]c]Y`]g]Yei`]ddYX`k]h`U`Vt]bj`YV]cb`Z]b]z`Ybg]fY`h`Uh]Ub`Y`VWf]W`ci`h`Yh]g]k`]h]b`*`Z]f]%, `a`k`cZ`h`Y`g]c]Y`"

j` H`Y`U`ck`cZ`Vt`a`Vi`g]h]cb`UbX`j`Ybh]Uh]cb`U]f`a`i`g]h]bch]VY`cVg]fi`WVX`"

7@95F 5B79G`HC`7CA 6I GH6@9G.

- 5" G]XYk U`hc`i`b]h` %\$]bWYg`f]B)`(`Vt`k`
- 6" 6UW]k U`hc`i`b]h` (`]bWYg`f]B`\$`&`Vt`k`
- 7" 7cfbYf`hc`i`b]h` &]bWYg`f]`"%`Vt`k`
- 8" 7ca`Vi`g]h]VYg]hc`i`b]h]h]cd`" `&&]bWYg`f]`)"`-`Vt`k`
- 9" :`ccf`hc`i`b]h`" \$]bWYg`f]B`Vt`k`
- : "5`Vt]Y`a`U`]a`i`a`XYdh.` (, `]bWYg`f]B`&`%-`Vt`k`

CLEARANCES MUST BE SUFFICIENT TO ALLOW ACCESS FOR MAINTENANCE AND SERVICE.

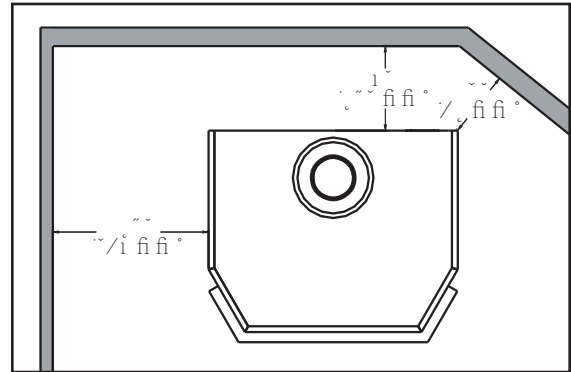

Figure 13: Clearances to combustibles.

: @ 9`; 5G`Gd`-@@`Gk`≡H7<.

NOTE: H.]g\YUHf`a`i`g]h]VY`dfcdYf m]bghU`YX`hc`U`j`Ybh]b[`gnghYa`" `H.]g\YUHf`]g]Yei`]ddYX`k]h`U`j`Ybh]gUZYh]m]g]i`hc`ZZ`gnghYa`XYg]l`bYX`hc`dfch]V]U[]b]gh]a`dfcdYf`j`Ybh]b[`cZ`Vt`a`Vi`g]h]cb`dfcXi`V]g`" `H.]g]gUZYh]m]g]k]h]W`]g`c`WVhYX`cb`h`Y`fYUf`cZ`h`Y`Udd`]UbW`Vt]gY`hc`h`Y`XfUz`h]ccX`fY`]YZ`cdYb]b[`"

=Z`h`Y`g]k]h]W`h]f]dg`a`cfY`h`Ub`cbWYz`h`Y`W]a`bYm`g`c`i`X`VY`]bgdYWhYX`Vm`U`e`i`U`]UYX`gYf]j]WY`hYW`b]W]Ub`Zcf`dcgg]V`Y`V`cW`U[`Y`cf`gY`j`YfY`Xc`kb`XfU`i`[`h`WcbX]h]cbg`"

=b]h]U` ` =b ghU` ` Uh]c b

E I 5@= 98 `B GH5@@9F G `C B @M

J 9BH=B; .

H\]g'a cXY`a i gh`Uj Y`Uj YbhcdYb]b[`]b`h`Y`fYUf`cZ`h`Y`i b]h`7cbUfa `h\]g`UbX`Ugc`W`Y`W`h`U`h`Y`U`V`Y`cb`h`Y`f][`h]g]XY`dUbY`Xccf`g`U`H`g`J`Y`b`h`Y`F`cca`<`Y`U`H`f`I`"

WARNING: H\]g`Udd`]UbW`U`Ug`V`Y`Y`b`X`Y`g][`b`Y`X`h`c`d`Y`f`U`H`V`m`i`X`f`U`k`]b[`V`e`a`V`i`g`h]`c`b`U`j`f`U`b`X`X`i`h]`c`b`U`j`f`Z`f`c`a`h`Y`f`c`c`a`" `H`Y`X`f`U`Z`h`c`c`X`c`W`U`H`X`]b`h`Y`g`U`a`Y`U`h`a`c`g`d`Y`f`W`d`f`Y`g`g`i`f`Y`n`c`b`Y`U`g`h`Y`V`e`a`V`i`g`h]`c`b`U`j`f`]b`Y`h`r`c`h`Y`U`dd`]UbW`" `h]g`U`g`c`X`Y`g][`b`Y`X`h`c`X`f`U`k`f`c`c`a`U`j`f`Z`c`f`d`f`c`d`Y`f`Y`U`h`V`Y`W`U`h]`c`b`Z`f`c`a`h`Y`f`Y`U`f`c`Z`h`Y`i`b]h`6`c`W`]b[`c`f`a`c`X`Z`h]b[`h`Y`c`i`j`Y`f`g`]b`U`b`m`i`k`U`m`W`U`b`V`Y`U`H`Y`U`h`U`f`X`c`i`g`g`h`U`h]`c`b`g`z`Y`h`Y`f`h`f`c`i`[`d`c`c`f`j`Y`b`h]b[`c`f`V`m`c`j`Y`f`Y`U`h]b[" `h]g`]a`d`c`f`U`b`h`h`U`h`h`g`i`b]h`U`g`g`i`Z`U`Y`b`h`U`j`f`V`Y`W`U`h]`c`b`Z`c`f`d`f`c`d`Y`f`j`Y`b`h]b[`U`b`X`V`e`a`V`i`g`h]`c`b`h`i`g`d`f`c`j`]g]c`b`g`a`i`g`h`V`Y`a`U`X`Y`Z`c`f`h`Y`g`i`d`d`m`c`Z`U`X`Y`e`i`U`H`Y`V`e`a`V`i`g`h]`c`b`U`b`X`Y`b`h]`U`h]`c`b`U`j`f`"

WARNING. C`d`Y`f`U`h]`c`b`c`Z`h`g`U`Y`U`H`f`k`Y`b`b`c`h`V`e`b`b`V`Y`W`X`h`c`U`d`f`c`d`Y`f`m]b`g`h`U`Y`X`U`b`X`a`U]b`h]b]b`Y`X`Y`b`h]b[`g`n`g`h`Y`a`c`f`h`U`a`d`Y`f]b[`k`]h`h`Y`j`Y`b`h]g`Z`Y`h`m`g`i`h`c`Z`g`n`g`h`Y`a`V`U`b`f`Y`g`i`h]b`V`U`V`c`b`a`c`b`c`l`X`Y`f`I`Z`C`k`d`c]g`c`b]b[`U`b`X`d`c`g]V`Y`X`Y`U`h`"

THE APPLIANCE CANNOT BE CONNECTED TO A CHIMNEY FLUE SERVICING A SEPARATE SOLID FUEL BURNING APPLIANCE.

A 5BI : 57H F 9F D; 9B9F 5@J 9BH=B; ; I =89@-B9G.

H\]g`]b`Z`c`f`a`U`h]`c`b`]g`V`e`a`d]Y`X`V`m`h`Y`a`U`b`i`Z`U`M`i`f`Y`f`U`g`U`j`Y`f`m][`Y`b`Y`f`U`f`i`Y`Z`c`f`g]b[`Y`U`dd`]UbW`j`Y`b`h]b[`c`Z`h`Y`9;`&`[`U`g`g`n`c`j`Y`k`]h`(`]b`W`h`h`d`Y`6`[`U`g`j`Y`b`h]`F`Y`Z`f`h`c`h`Y`j`Y`b`h]b[`a`U`b`i`Z`U`M`i`f`Y`f`U`X]f`Y`V`U`h]c`b`g`Z`c`f`]b`g`h`U`U`h]`c`b`"

J`Y`b`h]b[`V`e`X`Y`U`b`X`f`Y`i`U`h]c`b`g`a`U`m`j`U`f`m]Z`f`c`a`U`f`Y`U`h`c`U`f`Y`U`z`d`Y`U`g`Y`W`Y`W`k`]h`h`Y`c`W`z`g`h`U`H`#`d`f`c`j`]b`V]U`V`e`X`Y`g`f`Y`[`U`f`X]b[`h`Y`g`i`]h`U`V`]m`i`c`Z`m`c`i`f`U`dd`]U`h]`c`b`"

:`c`f`c`h`Y`f`g`d`Y`V]U`j`Y`b`h]b[`f`Y`e`i`]f`Y`a`Y`b`h`z`d`Y`U`g`Y`f`Y`Z`f`h`c`h`Y`c`W`z`g`h`U`H`#`d`f`c`j`]b`V]U`c`f`b`U`h]c`b`U`V`e`X`Y`g`"

H`Y`j`Y`b`h]b[`g`n`g`h`Y`a`g`l`c`i`X`V`Y`U`g`g`Y`a`V`Y`X`U`b`X`]b`g`h`U`Y`X`U`W`e`f`X]b[`h`c`h`Y`j`Y`b`h`a`U`b`i`Z`U`M`i`f`Y`f`U`]b`g`h`f`i`V`U]c`b`g`U`b`X`h`Y`c`W`z`g`h`U`H`#`d`f`c`j`]b`V]U`c`f`b`U`h]c`b`U`V`e`X`Y`g`"

; 9B9F 5@J 9BH=B; ; C F Hk 9 9, & .

H\]g`g`n`c`j`Y`g`l`c`i`X`V`Y`j`Y`b`h]X`V`m`W`f`h]U`Y`X`(`I`f`l`\$`V`a`E`h`h`d`Y`6`;`U`g`j`Y`b`h`c`f`U`U`Y`I`]V`Y`[`U`g`j`Y`b`h]b]b`Y`f`h`U`h`a`U`m`V`Y`Y`b`V`U`g`Y`X`]b`*`I`f`l`\$`V`a`E`X`Y`V`e`f`U`h]j`Y`g`n`c`j`Y`d]d`Y`" `H`Y`U`i`Y`V`e`U`f`c`Z`h`Y`U`dd`]UbW`k`]h]b]g]X`Y`c`Z`g`U`b`X`U`f`X`j`Y`b`h`U`b`X`a`U`m`V`Y`Z`U`g`h`b`Y`X`X]f`Y`V`U`m`i`r`c`h`Y`j`Y`b`h`"

H`Y`9`B`J`= `F`C`]b`V`e`f`d`c`f`U`H`g`]h`g`c`k`b`]b`h`Y`f`b`U`X`f`U`Z`h`c`c`X`z`g`c`b`c`U`X`X]h]c`b`U`Y`I`h`Y`f`b`U`X`f`U`Z`h`c`c`X`]g`f`Y`e`i`]f`Y`X`"

7`Y`W`d`Y`f]c`X]W`m`h`U`h`h`Y`j`Y`b`h]g`i`b`f`Y`g`h]V`Y`X`U`b`X`U`b`U`X`Y`e`i`U`H`Y`X`f`U`i`[`h]g`d`f`Y`g`Y`b`h`k`Y`b`h`Y`i`b]h]g`]b[`c`d`Y`f`U`h]`c`b`"

Technical Title

Technical Reference Code

Section Header

Technical description paragraph 1

Technical description paragraph 2

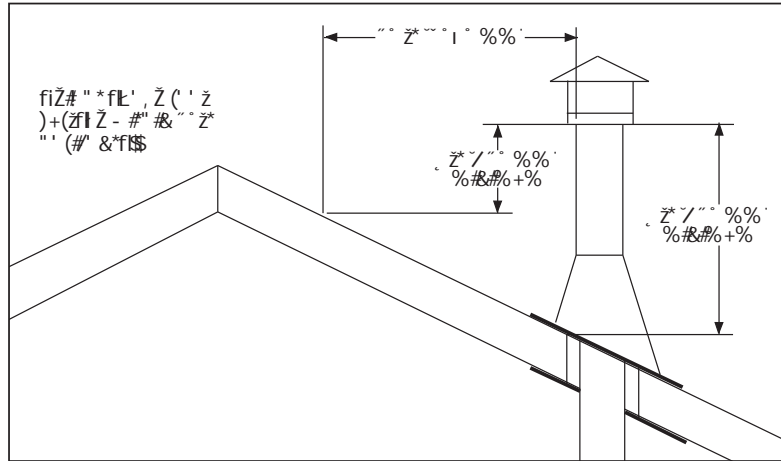

Figure 14: Height of Vertical Termination.

Technical Reference Code

Technical description paragraph 1

Technical description paragraph 2

Technical description paragraph 3

Technical description paragraph 4

Technical description paragraph 5

Technical description paragraph 6

Technical description paragraph 7

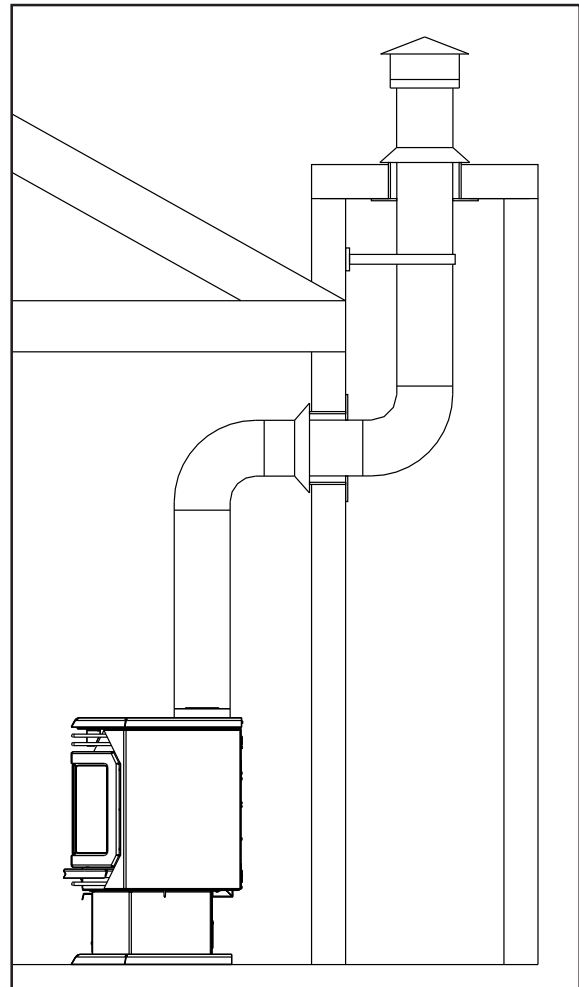

Figure 15: Installation into an existing chimney.

=b]h]U` ` =b ghU` ` Uh]c b

E I 5@= =98`-BGH5@@9F G`CB@M

Gf 5=, <HJ 9FH75@`-BGH5@@5H-CB.

H\]g\Ug]Vj Ybh]b[`VtbU[i fU]cb g\ck b`UfY`fci [\` [i]XY]bYg`cb`m` : c`ck `bU]cbU` UbX` `cW` VtXYg` Zcf`cH\Yf`]bgH`U]cb`cdh]cbg`

: cf`h`Y`VYghj Ybh]b[`dYfZcfa UbWzk YfVt`a a YbX` U`h`U`j`Ybh\Y][\h]b`h`Y`fUb[Y`cZ`\$`ZYhfI "\$`a`E` h`c` ` \$` ZYhfI f` "%`a`E` H`Y` h`U` \cf]ncbH` `Yb[h` XYdYbXg` cb` h`Y` bi`a`VYf` cZ` YVck`g` i`gYX`/` U` -`\$` YVck` U`Wt`i` brg` Zcf`)` ZYhfI f`%`)` a`E` cZ` h`Y` \cf]ncbH` `fi` b`"

H`Y`j`Ybh]b[`g\ci` X`bYj` Yf`g`cdY`Xck` bZ`U`a`]b]a` i`a` `]bW` f`\$`*` Vt`E` f]gY`]g`bYXYX` Zcf` Yj` YfmI` ZYhfI` f`%`Vt`E` cZ` \cf]ncbH` `]g`fYVt`a` a` YbXYX`"

=Z`dfU`M`V`Z`]h`]g` VYgh` h`c` `cW`h`Y` h`Y` Udd`]UbW` h`c` dYfa`]h` h`Y` i` gY` cZ` g\cfH`f` \cf]ncbH`U`g` UbX` ZYk` Yf` YVck`g`"

Table 3. 90° elbows allowed versus the horizontal length.

Bi`a`VYf`cZ`-\$` YVck`g`	A`U`]a` i`a` `h`U` \cf]ncbH` `Yb[h` U`ck`YX`
&	&\$` ZYhfI f` "%`a`E`
'	%` ZYhfI ("`\$`a`E`
(*` ZYhfI f`%` ,` a`E`
)	\$` ZYhfI f`\$`a`E`

B`c`h`Y` .`I` g]b[`h`c` f`&`E` ()` s` YVck`g`]g`Yei`]j` U`Ybh` `h`c` i` g]b[`cbY` f`%`E` -`\$` YVck`g`"

H`Y`j`Ybh]b[`f]gY` g\ci` X`VY`U`a`]b]a` i`a` `cZ`%`Z`ch` f`\$`" ` %`a`E` Z`ca` `h`Y` h`cd` cZ` h`Y` i` b]h` VYzcfY` Ubm` \cf]ncbH` `fi` b`UfY` i` gYX`"

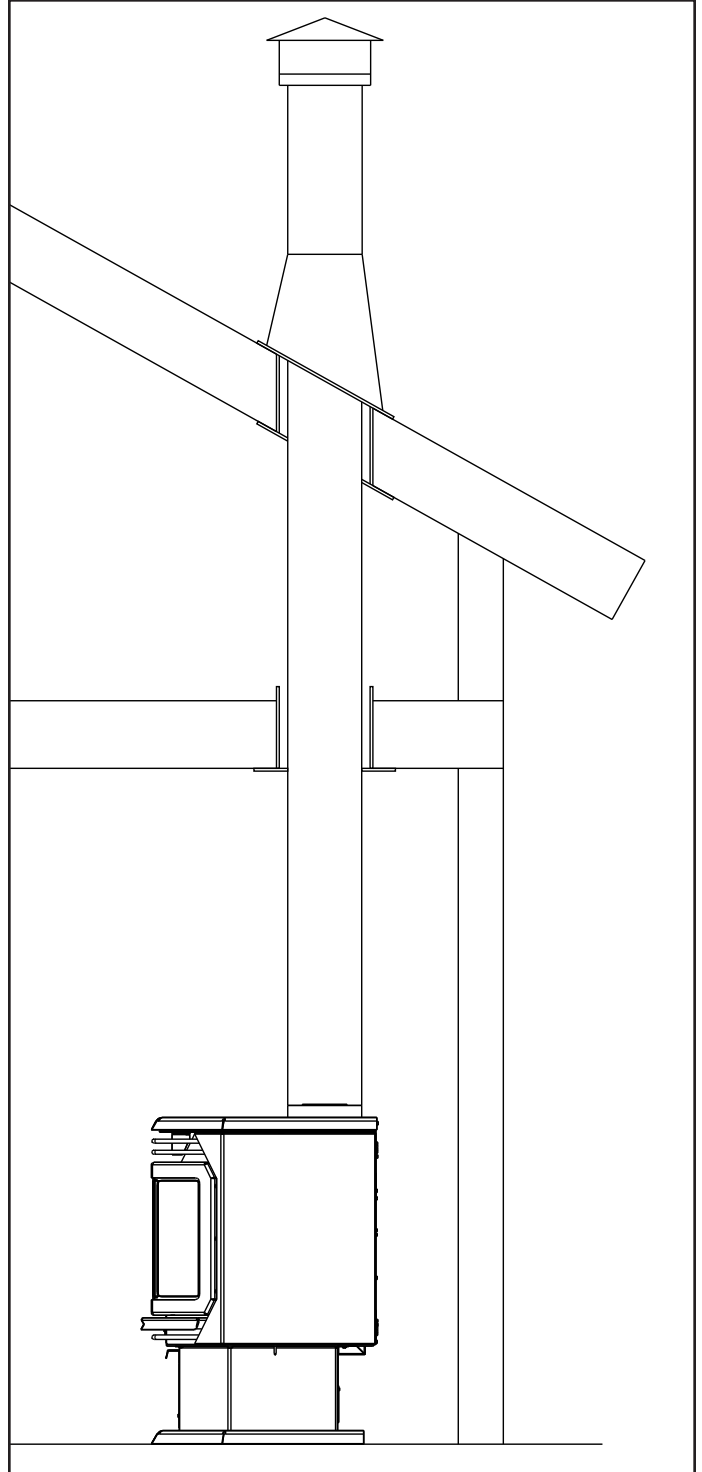

Figure 16: Straight vertical installation.

ENVIRO

EG28 BV

9@97HF =75@F 9EI =F 9A 9BHG.

H\Y' ENVIRO' 9, & 'k]''cdYfUHY' k]h'ci h'Y'Vf]W' dck Yf' H\g'a cXY' \Ug' U'a]''j' c'h [Ug' V'bf'c'z'k \]W' i'gYg'h'Y'd]ch'U'U'a Y'hc [YbYfUHY' Ybci [\ Y'Vf]W' m'hc'cdYfUHY' h'Y'a U]b' Vi' fbYfg' h'Y'Udd']UbW']g'Yei]ddYX' k]h' U' V'ck' Yf' UbX' a i' gh' VY' Y'Vf]W' m' V'bbY'V'X' UbX' [fci bXYX']b' U'V'f]W' k]h' 'c'V'W' V'X'Yg' cf']b' h'Y' U'V'g'Yb'W' c'Z' 'c'V'W' V'X'Yg'z' k]h' h'Y' W'ffYbh' 7G5' 7&&'%'75B58=5B' 9@97HF =75@7C89' DUfh'%'G5: 9HM' GH5B85F8G': CF' 9@97HF =75@ =BGH5@5H=CBG'Z' CF' H<9' B5H=CB5@9@97HF =75@7C89' 5BG= # B: D5' +\$']b' h'Y' I' "G"

WARNING: 9'Y'Vf]W' [fci bX]b []b'g'f' V'cb'g' H\g' Udd']UbW']g'Yei]ddYX' k]h' U' h'f'Y'! d'f'c'b ['f [fci bX]b ['L' d'i ['Z'c'f' n'c'i' f' d'f'c'h'V'cb' U [U]b'g'h' g'c'V' \U'U'f'X'z' UbX' a i' gh' VY' d'i [[YX' X]f'Y'V'f]W']b'hc' U' d'f'c'd'Y'f' m [fci bXYX' h'f'Y'! d'f'c'b ['c'i' h'Y'f' "

DO NOT W'h'c'f' f'Ya' c'j' Y' h'Y' [fci bX]b []d'f'c'b []Z'c'a' h'g'd'i ["

CAUTION: @VY' U'' k]f'Yg' d'f'c'f' h'c' X]g'V'bbY'V'cb' k \Yb' g'Yf'j']b []V'bf'c'g' K]f]b []Y'f'f'c'f'g' V'Ub' W'i' g'Y']a' d'f'c'd'Y'f' UbX' XUb [Y'f'c'i' g' c'd'Y'f'U'h'c'b' JYf]Z'm' d'f'c'd'Y'f' c'd'Y'f'U'h'c'b' U'Z'Y'f' g'Y'f'j']b ["

BCH9.

€#CdYfUh]cb' cZ' h'Y' ZUb']b'V'Y'U'g'Y'g' h'Y' YZ]V'Y'V'W'h' UbX' h'Y' \Y'U'h'ic'i' h'd'i' h'c'Z' h'Y' Udd']UbW'

€#H\Y' h'Y'f'a' c'g'h'U'h'V'bbY'V'g'h'c' h'Y' h'c' d'i' f'd'Y'k]f'Yg']b' h'Y' \U'f'b'Y'g'g'

€#7c'bf'c' d'UbY''] [\h'i' g'Y'g'U' + 'K' U'h'ia' U']' 'Vi' V'

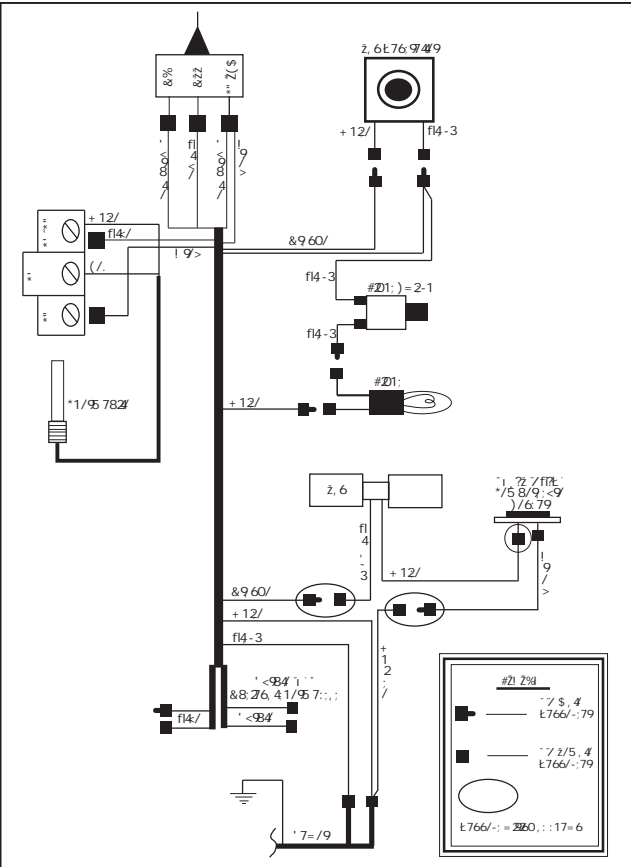

Figure 17: EG28 BV Wiring Diagram.

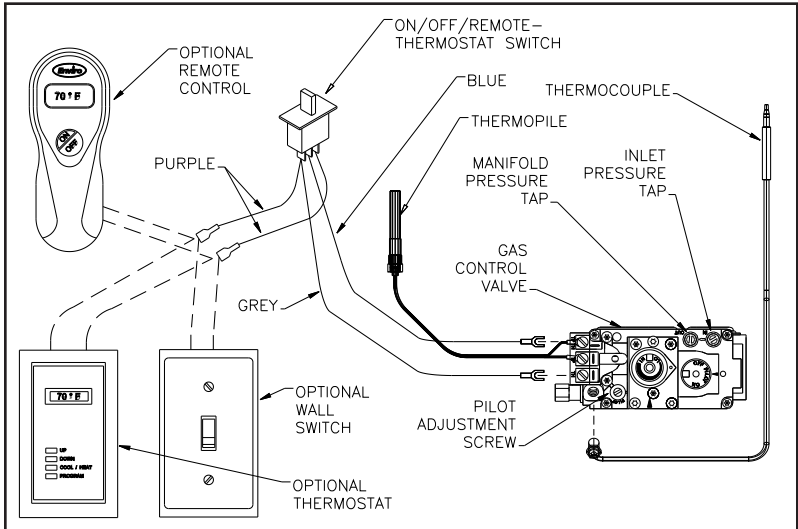

Figure 18: Wiring of a Thermostat

- €#If the unit is installed in a Mobile Home it must be connected to a grounding rod.
- €#If the unit is installed in a Mobile Home it must be bolted securely to the floor.

Table 4. Recommended Thermostat Wire Size.

K]f'Y'g'h'Y	A U']' @b [h
% [U'] Y	%\$ \$ Z'h' f] \$' (, ' a t
% [U'] Y	*\$ Z'h' f] %' &' a t
% [U'] Y	(\$ Z'h' f] %' \$ \$ a t
&\$ [U'] Y	&) Z'h' f] h' * &' a t
&& [U'] Y	% Z'h' f]) (- a t

≡b]h]U` ` ≡b ghU` ` Uh]c b

; 5G@B97CBB97HCB 5B8 HgHB; .

WARNING: Cb`midYfgcbg`WbgYX`rc`k`cf`_`k`h` [Ug`d]d]b[`a`Uma`U`Y`h`Y`b`YWggUfm[Ug`V`bb`YV]cbg`h`c`h`j`g`Udd`]UbW`"

GAS LINE CONNECTION

H`j`g`g`c`j`Y`j`g`Yei`j`dd`YX`k`h`U`W`fh]UYX`U`Y]`j`V`Y`d]d`Y`c`W`h`YX`c`b`h`Y`f][`h`g]XY`c`Z`h`Y`i`b]h`h`Y`f`a`]b`U`h]b[`]b`U` `I`a`U`Y`BDH`U`h]b[""7`cb`j`h`m`c`i`f`c`W`U`i`h`c`f]h`Y`g`V`c`X`Y`g`c`f`h`Y`7`5`B`#`7;`5`6`%`(-`f`%`c`f`&`l]b`g`U`U`h]c`b`V`c`X`Y`]b`7`U`b`U`X`U`z`c`f`]b`h`Y`I`G`5`[`U`g`]b`g`U`U`h]c`b`g`Z`c`k`Y`h`Y`f`c`W`V`c`X`Y`g`c`f`h`Y`W`f`f`Y`b`h`Y`X]h]c`b`c`Z`h`Y`B`U`h]c`b`U`:`i`Y`:`U`g`7`c`X`Y`5`B`G`=`N`&`&` "%`

H`Y`Y`Z`M`Y`b`W`h`f`U`h]b[`c`Z`h`j`g`U`dd`]UbW`]g`U`d`f`c`X`i`V`h`h`Y`f`a`U`Y`Z`M`Y`b`W`h`f`U`h]b[`X`Y`h`Y`f`a`]b`Y`X`i`b`X`Y`f`V`c`b`h]b`i`c`i`g`c`d`Y`f`U`h]b[`V`c`b`X]h]c`b`g`U`b`X`k`U`g`X`Y`h`Y`f`a`]b`Y`X`]b`X`Y`d`Y`b`X`Y`b`h`m`c`Z`U`b`m]b`g`U`Y`X`g`h`Y`a`"

H`Y`U`dd`]UbW`U`b`X`]h`g`g`i`h`c`Z`j`U`j`Y`g`a`i`g`h`V`Y`X]g`V`c`b`b`Y`V`W`X`Z`f`c`a`h`Y`[`U`g`g`i`d`d`m`d]d]b[`g`h`Y`a`X`i`f]b[`U`b`m`d`f`Y`g`g`i`f`Y`h`Y`g`h]b[`k`Y`f`Y`h`Y`d`f`Y`g`g`i`f`Y`Y`I`W`Y`X`g`:`D`G`= `f`l`"`) `?`D`U`L`c`f`X`U`a`U`[`Y`k`]`c`W`W`f`h`c`h`Y`j`U`j`Y`"

H`Y`U`dd`]UbW`a`i`g`h`V`Y`]g`c`U`h`Y`X`Z`f`c`a`h`Y`[`U`g`g`i`d`d`m`d]d]b[`g`h`Y`a`V`m`V`c`g]b[`]h`g`]b`X]j`X`i`U`a`U`b`i`U`g`i`h`c`Z`j`U`j`Y`X`i`f]b[`U`b`m`d`f`Y`g`g`i`f`Y`h`Y`g`h]b[`c`Z`h`Y`[`U`g`g`i`d`d`m`d]d]b[`g`h`Y`a`U`h`h`Y`g`h`d`f`Y`g`g`i`f`Y`g`Y`e`i`U`h`c`c`f`Y`g`g`h`U`b`:`d`g][`f`l`"`) `?`D`U`L`"

Always check for gas leaks with a soap and water solution after completing the required pressure test.

TO TEST VALVE PRESSURES

H`Y`d`f`Y`g`g`i`f`Y`h`U`d`g`U`f`Y`c`W`h`Y`X`c`b`h`Y`Y`Z`h`g]XY`c`Z`h`Y`j`U`j`Y`
 #H`b`g`Y`h`g`V`W`k`%`h`f`b`V`c`i`b`h`Y`f`V`c`W`k`]g`Y`h`c`c`c`g`Y`b`z`
 #D`U`W`Y`#`%`I`f]`a`a`L`="8""`c`g`Y`c`j`Y`f`d`f`Y`g`g`i`f`Y`h`U`d`g`h`Y`a`"
 #7`Y`W`d`f`Y`g`g`i`f`Y`g`i`g]b[`U`a`U`b`c`a`Y`h`Y`f`
 #K`Y`b`U`b]g`Y`X`z`f`Y`Y`U`g`Y`d`f`Y`g`g`i`f`Y`z`f`Y`a`c`j`Y`c`g`Y`/`h][`h`Y`b`g`Y`h`g`V`W`k`"

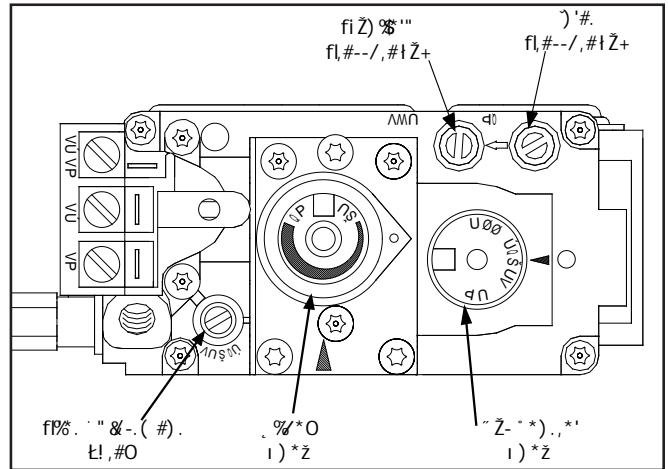

Figure 19: Fully Labeled Gas Valve.

Table 5: Pressure and BTU Information.

	Natural Gas	Propane
Main Orifice	(`8AG) `8AG
Manifold Pressure	' ", I`K`7" `f\$`-) ?DUL	%&"\$I`K`7" `f&"+ (?DUL
Min. Manifold Pressure	%%& `K`7" `f\$`&+ ?DUL	&"+I`K`7" `f\$`*+ ?DUL
Max Supply Pressure	+"\$I`K`7" `f%"+ (?DUL	%&"\$I`K`7" `f&`- , ?DUL
Min. Supply Pressure) "\$I`K`7" `f%&) ?DUL	%%) I`K`7" `f&` , * ?DUL
Max BTU/hr Input	&* z) \$\$`6HI`#`f`f`+ , ?K`L	&* z) \$\$`6HI`#`f`f`+ , ?K`L
Min. BTU/hr Input	% z) \$\$`6HI`#`f`f`- , ?K`L	% z) \$\$`6HI`#`f`f`- , ?K`L

NEVER USE AN OPEN FLAME FOR LEAK TESTING.

G YWc b XUf mi =b ghU` ` Uh]c b

=BG5@5H=CB`C: `@C; `G9H`5B8`9A69FG.

H\Y` d`UWa Ybh` cZ` h\Y` `c[g]` jg` bch`
 UFV]fUfm` =Z` h\Ym` UFY` dcg]h]cbYX`
]bVtffYVh`h\Y`Ua` YgVWb` VY`i`d]bWYX`
 UbX`k`j`bch`Vi` fb`VtffYVh`m`h\Y`Vi` fbYf`
 Vt`a`Y`k`]h`Uj`Y`f` E`cWUrc`d]bg`UbX`k`c`
 f&L`fYg]b[`UFYUg`z`k` \]W`a` U`Y`U`[`ba` Ybh`
 YUg]Yf` `I`g]b[`h\Y` d]Vh` fYg` dfcj`]XYX`
 WfYZ` `mgYh`h\Y` `c[g]` b`d`UW`

NOTE: The logs are fragile and should be handled gently.

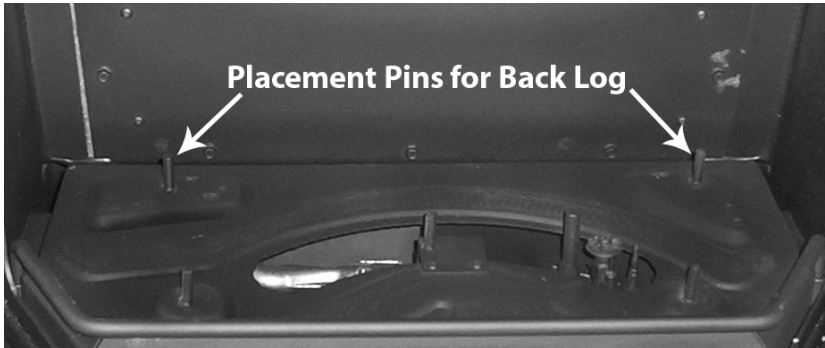

Figure 20: Step 1 of Log Placement.

CAUTION: I`gY`cb`m`h\Y`h`m`d`Y`c`Z`Ya` VYf`
 a`UHf]U` `g` dd`]YX` `k`]h` `h`g` Udd`]UbW`"
 8i`Y`hc` h\Y`]fY[`i` `Uf`g]h`Y`c`Z`h\Y`Ya` VYf`
 a`UHf]U` `h`YfY` `a`Um` VY` `a`cF` `h`Ub`
 fYei`]fYX`" h\Y` i`gY` `c`Z` ch`Yf` `Zc`fY][`b`
 a`UHf]U`g` `cb` `h\Y` `Vi` fb`Yfg` `a`Um` VYUHY`
 XU`b[`Yfci` g`Vt`bX]h]cbg`

=Z` cj`Yf` `h`a` Yz` h`fci` [` \ ` VWUb]b[` UbX`
 gYfj`]V]b[`z` h`YgY` `Ya` VYfg` `fYei`]fY`
 fYd`UWa` Ybh`z` Vt`b`UW` h\Y` b`YUfYgh`
 9BJ`=C` XYUYf` `Zc`f` fYd`UWa` Ybh`
 Ya` VYfg`

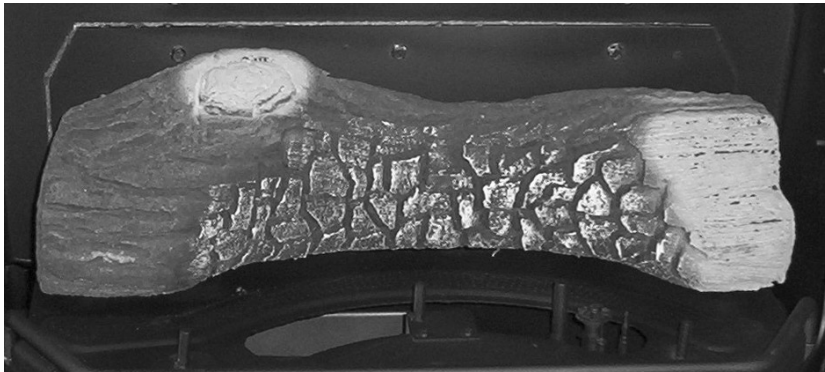

Figure 21: Step 2 of Log Placement.

%` h\Y` Ya` VYfg` WUb` VY` d`UW` VYz`c`fY`
 c`UZYf` h\Y` `c[g]` UFY` d`UWX`" 5` VU[`c`Z`
 WfUa`]W`U`VYf` `Ya` VYfg` UbX` `fcW` `k`cc`
 Ya` VYfg`]g` dfcj`]XYX` [`Ybh`m`fYa` cj`Y` h\Y`
 Ya` VYf` `a`UHf]U` `Zca` `h\Y` d`Ugh]WVU[`"
 GdfYUX` `U` `Uh`Yf` `ccgY`m`]b` `U` fUbXca`
 a`UbbYf` UW`cgg`h\Y`Vi` fb`Yf` fUhm` 8c`bch`
 U`ck` `Ubm`Ya` VYfg` `hc` fYgh`U[`U]bgh`d]`ch`
 UggYa` V`m` fGY` :][`i` fY` %` `cf` %` `Zc`f`
 dfcdYf`Ya` VYf` d`UWa` Ybh`z`

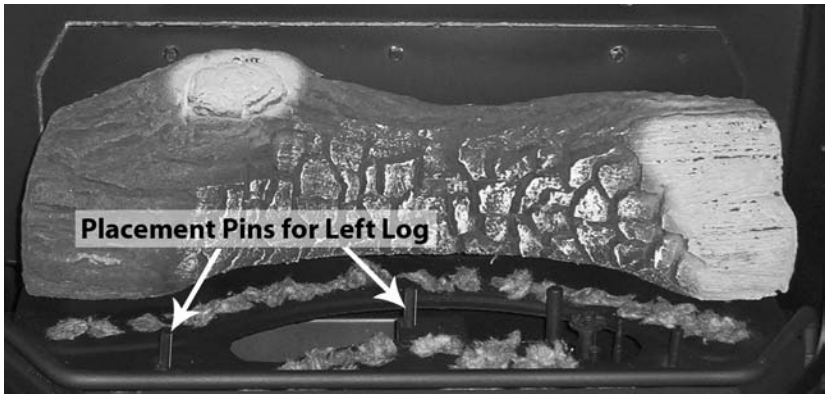

Figure 22: Step 3 of Log Placement.

8C` BCH` d`UW` `h`g` Ya` VYf` `a`UHf]U` `Ug`
 h`g` Vt`i` `X` VYUHY` `Ub` `i` bgUZ` Vt`bX]h]cbz`
 `YUj`Y`Ya` VYfg` `ccgY`

&` 7UFYZ` `m` fYa` cj`Y` `c[g]` `Zca` `Vcl`"
 7\YW` `hc` Ybgi` fY` h`YfY`]g` bc` XUa` U[`Y`
 `h`]g` j`Yfm`]a` dcfUbh` `hc`]bgh`U` `U` `c[g]`
]b` h\Yf` dfcdYf` dcg]h]cb` `hc`]bgi` fY` gUZ`z`
 cd]h`a` i` a` cdYfU]b[`Vt`bX]h]cbg`



Figure 23: Step 4 of Log Placement.

G YWc b XUf mi =b ghU` ` Uh]c b

' "' D'UW' h'Y`c['gyh]bhc' h'Y' ŪfYVcl "'
 @W'HY' YUW'`c['VmgyU'h]b[']h' Xck b'
 cbhc' h'Y' Vi fbYf' f'Umgi ddcfh d]bg"
 : c`ck` : [i fYg' %% hc' %*` dfcdYf'`c['
 d'UW'a Ybh'

(" I dcb' h'Y' Ūfgh`][\hi dż'k U'W' Zcf'
][b]h]cb' hc' **ALL** Vi fbYf' dcfhg'"` =Z U'
 `cb['XY'Um]g' bchYX. :]fgh' k U]h' Zcf'
 h'Y' Udd]UbW' hc' V'hc'`Xck b"

CdYb' h'Y' Zcbh' Xccf' cZ h'Y'
 Udd]UbW"

7\YW' hc' W'fYZ' `m'fYdcg]h]cb' h'Y'
 Ya VYfg' a U_]b[' gi fY' h'U'h' Vi fbYf'
 dcfhg' ŪfY' bch' d'i [[YX' gc`X' cf'
 VcWYX"



Figure 24: Step 5 of Log Placement.

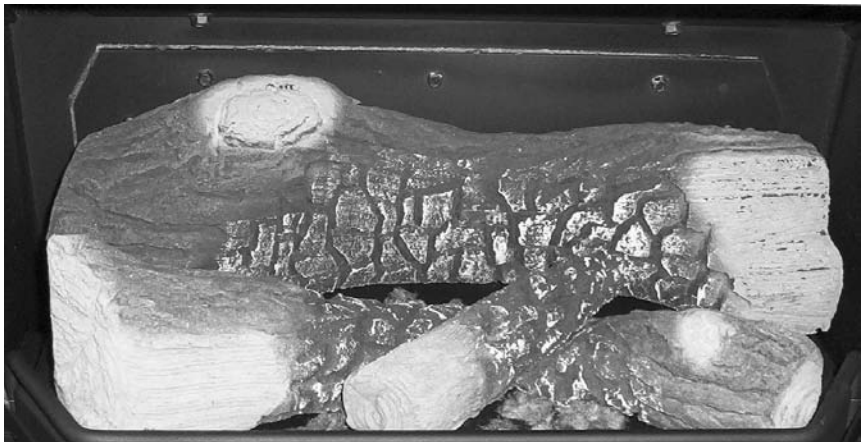

Figure 25: Log Placement with Embers.



Figure 26: Appliance Burning.

CAUTION: NEVER OPERATE THIS APPLIANCE WITH THE GLASS DOOR REMOVED.

Hf ci V`Y`G\cch]b[

Problem	Possible Cause	Solution
H\Y`a U]b`Vi fbYf` XcYg`bch`][b]h` k\Yb`W`YX`Zcf`	H\Y [Ugj Uj Y`a UmbchVY`cb"	i`7\YW`h`Uh`h`Y`[Ug`V`bfc``_bcV`]g`]b`h`Y`f`CBi`dcg]h]cb"
	H\Yfa cghU]g]bchW`]b[`Zcf` `YUH`	i`5X1`gh`h`Y`h`Yfa cghU]g]YfU`XY[fYg`UVcj`Y`Ua`V]Ybh`h`Ya`dYfU`h`fY"
	DfcVYa`k`]h`[Ugj Uj Y`	i`l`gY`U`87`j`c`h`a`Y`h`f`h`c`a`Y`U`g`i`f`Y`h`Y`j`c`h`U`[`Y`U`M`f`c`g`g`h`Y`H`D`H`<`U`b`X` H`D`h`Y`f`a`]b`U`g`A`U`]b`c`d`Y`f`U`h`c`f`j`c`h`U`[`Y`C`d`Y`b`V]f`W`]h`~` `&`a`J`7`c`g`Y`X` V]f`W`]h`~``%`\$`a`J` i`Z`j`c`h`U`[`Y`]g`b`c`h`d`f`Y`g`Y`b`h`z`W`Y`W`_`h`Y`V`b`f`c``V]f`W`]h`Z`c`f`d`f`c`d`Y`f` c`d`Y`f`U`h]c`b`" i`Z`d`f`c`d`Y`f`V`b`f`c``g`n`g`h`Y`a`j`c`h`U`[`Y`]g`d`f`Y`g`Y`b`h`z`f`Y`d`U`W`_`h`Y`[`Ug`V`b`f`c`"
GdUf`_`k`]`b`ch`][`h`h`Y`d]`ch` U`Z`h`f`f`Y`d`Y`U`h`X`m` d`f`Y`g`g`]b[`h`Y` g`d`U`f`_`][`b]h`c`f`	8YZV]V]j`Y`d]Ync`][`b]h`c`f`	i`7\YW`V`b`b`Y`M]c`b`g`h`c`][`b]h`c`f` i`Z`][`b]h`c`f`V`b`b`Y`M]c`b`g`U`f`Y`[`c`c`X`V`i`h`b`c`g`d`U`f`_`z`f`Y`d`U`W`_`][`b]h`c`f`
	6fc`_`Yb`g`d`U`f`_`Y`Y`M`f`c`X`Y`	i`7\YW`Z`c`f`V`f`c`_`Y`b`W`f`U`a`]W]b`g`i`U`h]c`b`z`f`Y`d`U`W`_`Y`Y`M`f`c`X`Y`Z`V`f`c`_`Y`b`
	A`]g`U`][`b`Y`X`g`d`U`f`_`Y`Y`M`f`c`X`Y`	i`Z`g`d`U`f`_`]g`b`c`h`U`f`M]b[`Z`c`a`Y`Y`M`f`c`X`Y`h`c`d]`c`h`z`c`c`g`Y`b`h`Y`g`M`Y`k`g`c`b`h`Y` d]`c`h`V`U`g`Y`U`X`1`g`h`U`b`X`h]`[`h`Y`b`"
D]`c`h`k`]`b`ch` f`Y`a`U`]b`]`h`	DfcVYa`k`]h`h`Y`f`a`c`V`e`i`d`Y` V]f`W`]h`	i`7\YW`Z`c`f`d`f`c`d`Y`f`V`b`b`Y`M]c`b`c`Z`h`Y`h`Y`f`a`c`V`e`i`d`Y`h`c`h`Y`f`Y`U`f`c`Z`h`Y` j`U`j`Y`~`Z`c`c`g`Y`Z`~`m]h]`[`h`Y`b`" i`7\YW`d]`c`h`Z`c`f`Z`~`U`U`a`Y`]a`d]b[`Y`a`Y`b`h`U`f`c`i`b`X`h`Y`f`a`c`V`e`i`d`Y`~`Z`U`U`a`Y`]g`h`c`c`g`a`U`z`W`Y`W`[`U`g`d`f`Y`g`g`i`f`Y`z`U`X`1`g`h`d]`c`h`f`U`h`g`M`Y`k`z`W`Y`W`d]`c`h` `Y`U`X`Z`c`f`X`U`a`U`]`Y`" i`7\YW`h`Y`f`a`c`V`e`i`d`Y`j`c`h`U`[`Y`U`h`j`U`j`Y`~`h`a`i`g`h`V`Y`[`f`Y`U`h`f`h`U`b`)`a`J`~` Z`c`k`z`f`Y`d`U`W`_`h`Y`f`a`c`V`e`i`d`Y`"
	5]f`]b[`[`U`g`]b`Y`f`d]`c`h`X]Y`g`k`\\`Y` _`bcV`]g`X`Y`d`f`Y`g`g`Y`X`E`	i`6`Y`Y`X`~`]b`Y`" i`7\YW`[`U`g`]b`Y`d`f`Y`g`g`i`f`Y`" i`7`c`b`h`U`M]X`Y`U`Y`f`"
6i`f`b`Y`f`g`k`]`b`ch` f`Y`a`U`]b`]`h`	DfcVYa`k`]h`h`Y`f`a`c`d]Y` V]f`W`]h`	i`7\YW`[`U`g`]b`Y`d`f`Y`g`g`i`f`Y`" i`7\YW`Z`c`f`U`U`a`Y`]a`d]b[`Y`a`Y`b`h`c`b`h`Y`f`a`c`d]Y`~`Z`c`k`z`g`Y`Y`[`D]`c`h`k`]`b`ch` f`Y`a`U`]b`]`h`" i`7\YW`h`Y`f`a`c`d]Y`Z`c`f`a`]b]a`i`a`c`Z``\$`\$`a`J`k`\\`Y`b`Vi`fb`Y`f`]g`k`]h`W`Y`X` `c`b`" i`7\YW`k`]f]b[`h`c`h`Y`f`a`c`g`h`U`h`Z`c`f`V`f`Y`U`_`g` BV ONLY: 7\YW`Z`c`f`g`d]`U`[`Y`U`h`X`f`U`Z`h`c`c`X`h`U`h`i`a`U`m]f`d]`g`d]`g`k`]h`W`
:`U`a`Y`~`]z]b[@`U`_`]b`j`Y`b`h`d]d`Y`	i`7\YW`Z`c`f`~`Y`U`_`g`]b`j`Y`b`h`V`b`b`Y`M]c`b`g`"
	=a`d`f`c`d`Y`f`j`Y`b`h`V`b`U`[`i`f`U`h]c`b`	i`7\YW`j`Y`b`h`V`b`U`[`i`f`U`h]c`b`k`]h`a`U`b`i`U`"
	H`Y`f`a`]b`U`a`U`m`V`Y`f`Y`V]f`W`U`h]b[` U`i`Y`[`U`g`Y`g`	i`7\YW`h`c`g`Y`Z`h`Y`f`a`]b`U`]g`c`b`V`e`f`Y`V`h`h` i`A`U`m`b`Y`Y`X`h`c`]b`g`U`~`][`k`]b`X`h`Y`f`a`]b`U`h]c`b`V`U`d`" i`7`c`b`h`U`M]X`Y`U`Y`f`"
;`U`g`g`Z`c`[`g`i`d`	B`c`f`a`U`7`c`b`X]h]c`b`U`Z`h`f`h`Y`U`d`d]U`b`W`k`U`f`a`g`i`d`h`Y`[`U`g`g`k`]`W`U`f` f`f`8`i`Y`h`c`U`X`X]h]j`Y`g`]b[`[`U`g`z`[`U`g`g`a`U`m`[`Y`h`U`m`i`X`i`f]b[`c`d`Y`f`U`h]c`b`f`f`7`Y`U`b`U`g`b`Y`Y`X`Y`X`"	
6`i`Y`:`U`a`Y`g`	B`c`f`a`U`X`i`f]b[`g`h`U`f`h`i`d`U`U`a`Y`g`k`]`m`Y`~`c`k`U`g`h`Y`U`f`Y`d`U`W`_`Y`U`h`g`i`d`"	
:`U`a`Y`g`U`f`Y` Vi`fb]b[`[`X]f`m]i`c`f` g`c`c`h]b[:`U`a`Y`]a`d]b[`Y`a`Y`b`h`	i`7\YW`~`c`[`d`c`g]h]c`b]b[`" i`b`V`Y`U`g`Y`d`f]a`U`f`m]U]f`V`m`c`d`Y`b]b[`h`Y`j`Y`b`h`f]g`i`h`Y`f`U`b`X`#`c`f`V`m` c`d`Y`b]b[`h`Y`j`Y`b`h`f`Y`g`f]M]c`f`" G`Y`Y`U`g`c`[`6`i`f`b`Y`f`g`k`]`b`c`h`f`Y`a`U`]b`]`h]f`"
F`Y`a`c`h`V`b`f`c`~` X`c`Y`g`b`i`k`c`f`_`	DfcVYa`k`]h`h`Y`f`Y`a`c`h`Y`	i`C`b`Y`c`f`a`c`Y`c`Z`h`Y`V`U`h`Y`f]Y`g`U`f`Y`X`Y`U`X`"G`Y`Y`f`Y`a`c`h`V`b`f`c`~`]b]g`f`i`V]h]c`b`g`"
	DfcVYa`k`]h`U`f`Y`d`U`W`	i`h`Y`c`b`#`Z`Z`g`k`]h`W`]g`h`i`f`b`Y`X`h`c`:`:`" i`h`Y`[`U`g`V`b`f`c`~`j`U`j`Y`]g`h`i`f`b`Y`X`h`c`D`=@`C`H`c`f`C`:`:`" i`h`Y`d]`c`h`\\`U`g`[`c`b`Y`c`i`h`"
BV ONLY: =b`g`Z`U`M]Y`b`h`U]f` Z`c`f`V`e`a`Vi`g`h]c`b`	i`5]f`h]`[`h`h`c`i`g`Y`" i`5`j`U`W`i`a`]b`f`c`c`a`X`i`Y`h`c` c`h`Y`f`U]f]a`c`j`]b[`X`Y`j`]W`"	i`G`i`d`d`m`a`U`_`Y`i`d`U]f`h`c`h`Y`i`b]h`"

DUF hg '@]gh

Reference Number	Part Description	Part Number
%	%&\$s: 'f(-s7L7YfUa]MhYa dYfUhi fY'GYbgcf	97!\$\$%
&	Gd]`Gk]hW`&&\$s: 'f%&%67L	97!\$\$&
'	H\Yfa cWti d'Y	97!\$\$-
'	GdUf_'9YVfCXY'k]h`7UV'Y'	97!\$%&
'	H\Yfa cd]Y	97!\$%&
'	D]chB;`k]h`9YVfCXY	97!\$%
'	D]ch@D'k]h`9YVfCXY	97!\$%(
'	: i`m5ggYa VYX'D]chB;	97!\$%&
'	: i`m5ggYa VYX'D]ch@D	97!\$%&
'	D]chCf]UW`B;	97!\$%
'	D]chCf]UW`@D	97!\$\$&
	D]ch;`Ug_Yh	97!\$\$&
(G`="H'D]Ync`=[b]hcf	97!\$&'
	GhU]b`Ygg`GHY`':`YI`7cbbYVfC'k]h`'#`I`9Vck`%'I`@cb[97!\$&(
)	6i`fbYf`Gk]hW	97!\$&)
	: Ub`5WVgg`7cj`Yf';`Ug_Yh	97!\$&-
*	A]b]Uhi`fY`@[`h6i`V`!`%&`J	97!\$`%`
*	@[`h6i`V`<c`XYf	97!\$`&`
	K]f]b[`<UfbYgg`7ca`d`YH`fB`d]YVWgJ	97!\$`+`
	6i`fbYf`K]f]b[`<UfbYgg	97!\$`+5`
	6cXmK]f]b[`<UfbYgg	97!\$`+6`
	: Ub`7cbhfc`Yf`?bcV	97!\$((\$
	=97`Dck`Yf`7cfX`!`%&`J	97!\$(('
	(cn`6U[`7cU`9a`VYfg`Cb`m	97!\$(()
	@[`GYhk]h`9a`VYfg	97!\$(,
	5`i`a]bi`a`A`Ub]Z`X	97!\$(-
+	%`I`%`G]XY`7UM]bYh<]b[`Y	97!\$)(
,	DYXYghU`8ccf`A`U[`bYh	97!\$)*
	'`#`I`HUXdc`Y`8ccf';`Ug_Yh]f]h`ZYfL	97!\$)+
-	8ccf`@UW`6c`h	97!\$)-
	: Ub`=a`dY`Yf	97!\$*(
	8ccf`Bi`hA`ci`bh]b[`6fUW]Yh	97!\$*)
%\$	@[`hGk]hW	97!\$**
%%	: Ub`7cbhfc`Yf`k]h`?bcV`!`%&`J	9`!\$()
%&	G]XY`DubY`A`U[`bYh`6fUW]Yh	9;`&`!\$&+
	9bj]fc[`Ug`9;`&`BLa`Y`DUY	9;`&`!\$+*
	@UW`6fUW]Yh`UbX`Bi`h	9;`&`!\$-)
%	7ca`d`YH`-bbYf`8ccf`k]h`';`Ugg	9;`&`!%\$'
%{	DYXYghU	9;`&`!%\$,
%&	DYXYghU`8ccf	9;`&`!%\$-

DUF hg '@]gh

Reference Number	Part Description	Part Number
%*	6i fbYf HFUmHcd	9; &!%* 5
	6J`Ck bYfGj`A Ubi U`	9; &!%&%
%+	7UV]bYhGjXY`DubY`	9; &!%&!
%	6J`Grcj Y`Hcd	9; &!%&(
	:]fYVcl`6UZjY	9; &!%&)
	: Ub`?`]h	9; &!%&+
%	6J`Hcd`6UZjY	9; &!% &
&\$	K]fY`7\UbbY`	9; &!% -
	DYXYghU`K]f]b[`DUHY	9; &!%(\$
&%	DYXYghU`6UW	9; &!%(%
&&	5g\`G\YZ	9; &!%\$
	8ccf`<]b[Y`6fUWYh	9; &!%*%
&'	8ccf`@JHW`6fUWYh	9; &!%* &
&(6J`(T`7f]a dYX: `i Y`D]dY	9; &!%* -
&)	; `UggGYhk]h` ; Ug_Yh	9; &!%\$)
	H\Yfa cWdi d`Y`D]chBi h	9; &!%&\$
&*	: Ub`A ci bh]b[`6fUWYh	9; &!` \$(
&+	JYbhi f]	9; ` %\$ - -
	7cbfbc`DubY`8YWW	` \$!\$((
	FYUF`9I hf]cf`6UW`DubY`	` \$!\$()
&,	7cbfbc`DubY` : fcbhUbX`8YWW	` \$!\$* -
	6`ck Yf`A ci bhG\WYk g`f(k) \$!\$, *
&-	6`Ub`Cf]UW` . +() \$!` ('
` \$; `Ugg`9I hfi gjcbgfbYhcZ&k) \$!(, '
` %	7cbj YW]cb`6`ck Yf`!`%&J`fbc`a ci b]k) \$!)%&
	%T`=[b]hcf`K]fY) \$!*) &
` &	G`="H`BCJ5`JUj Y`7cbj Yfh]VY) \$!%(&%
	7cbj Yfg]cb`?`]h@`Hc`B; `7cbj Yfh]VY) \$!%(` \$
	7cbj Yfg]cb`?`]hB; `Hc`@`7cbj Yfh]VY) \$!%(` %
	G`="H`JUj Y`7cbj Yfg]cb`G\WYk`k`]h`C!`f]b[) \$!%(\$
	G`="H`JUj Y`7cbj Yfg]cb`G\WYk`7Ud) \$!%(%
''	6Uf`GYhf(`D]YWgk`!`B]M]Y`) \$!(+)
''	6Uf`GYhf(`D]YWgk`!`DU]bhYX	9; &!%&
''	6Uf`GYhf(`D]YWgk`!`; c`X	9; &!%` '
' (8ccf`7cj Yf`!`; c`X) \$!(+*
' (8ccf`7cj Yf`!`DU]bhYX) \$!+) +
' (8ccf`7cj Yf`!`6fi g\YX`B]M]Y`) \$!%\$*(
')	8ccf`5ggYa Vm]k]h` ; `Ugg`fBZ`6k`!`6fi g\YX`B]M]Y`) \$!%\$*)
')	8ccf`5ggYa Vm]k]h` ; `Ugg`fBZ`6k`!`DU]bhYX	9; &!\$ - -
')	8ccf`5ggYa Vm]k]h` ; `Ugg`fBZ`6k`!`; c`X	9; &!%\$%

Duf hg '8]U[f Ua '! '7 \ Ugg]g

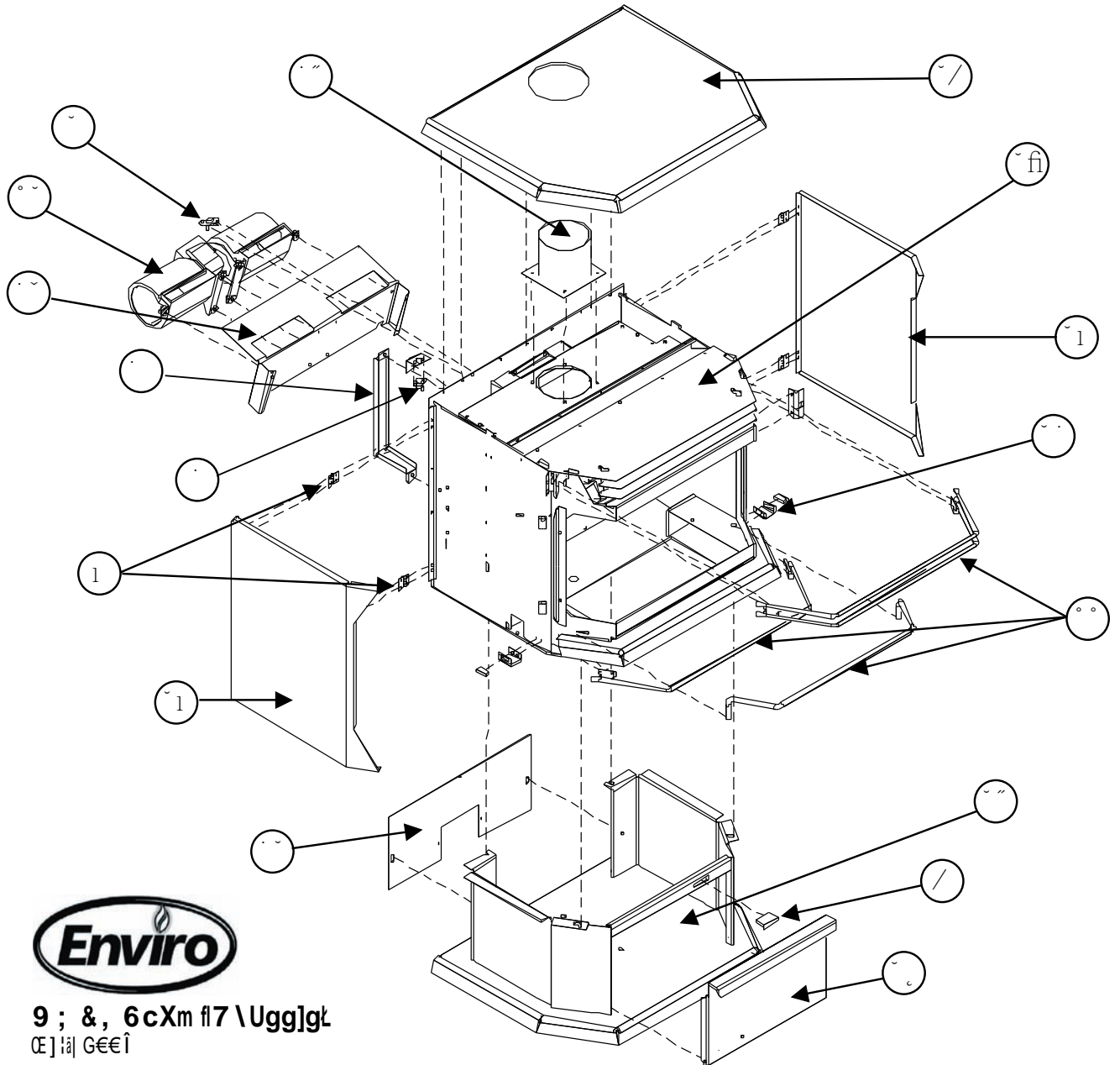

9 ; & , 6cXm fl7 \ Ugg]gł
œ]!aj G€€Ī

DUf hg '8]U[f Ua '!'; Ug 'Hf Um/ '8 c c f



9 ; & , ; Ug HfUm UbX 8ccf 5ggYa V'Yg
œ]i| Gœœi

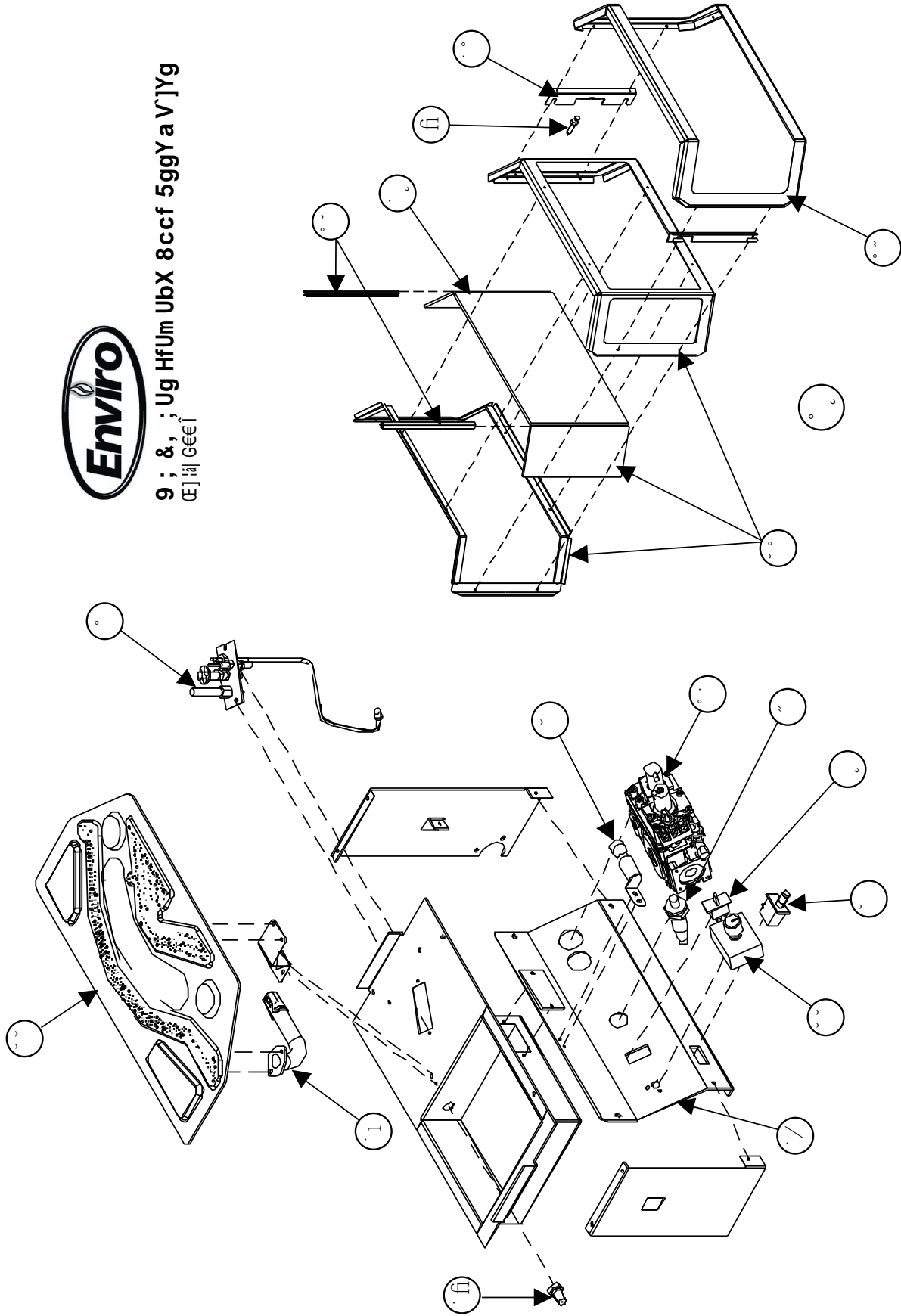

K Uf f Ub hm

G\Yfk ccX' =bXi gfr]Yg' @X'' Jg h\Y' a Ubi ZUMi fYf' cZ h\Y' 9bj]fc' ']bY' cZ \YU]b[' dfcXi Vltg' 5h G\Yfk ccX' =bXi gfr]Yg' ci f' Vta a]ra Ybh'hc' h\Y' \]] \Ygh' Yj Y' cZ ei U]hmUbX' Wg'ca Yf' gYfj]W']g' h\Y' a cgh]a dcfU]bhi h]b[' k Y'Xc'' 9UW' 9bj]fc' g'c] Y']g' Vi]h'cb' U' h'fUX]h'cb' cZi]g]b[' cb'm'h\Y' UbYgh'a UHf]Ug' UbX']g' VUW\YX' Vm' ci f' 9l W' g]j Y' @ZY]a Y' @]a]h\X' K UffUbhm'hc' h\Y' cf]]]bU' di f\W'UgYf' K]h' 9bj]fc'z' nci]Y' bch' f' gh' Vi n]b[' U' UfYd'UW' cf' g'c] Y'z' nci]Y' Vi n]b[' U' Vta dUbmik]h' n\Y'Ufg' cZi bYei U' YX' dYfZcfa UbW' UbX' ei U]m'

Limited Lifetime Warranty:

I bXYf' h]g' k UffUbhm' G\Yfk ccX' =bXi gfr]Yg' @X'' Vtj Yfg' h\Y' UfYd'UW' cf' g'c] Y' VcXm'UbX' UWW'ggc]f]Yg' U[U]bghi XYZVltg']b' a UHf]Ug' UbX' k cf_a Ubg\]d'z' Zcf' dUfh' fYdU]f' cf' fYd'UW'a Ybh' Zcf' h\Y' Ufgh' gYj Yb' fl'k' n\Y'Ufg' UbX']a]h\X' U'Vci f' Zcf' h\Y' Ufgh' k c' f&k' n\Y'Ufg' hc' h\Y' cf]]]bU' di f\W'UgYf' H]g' K UffUbhm' Vtj Yfg' :]fYVcl z' < YUhi 9l W'Ub[Yfz' GHY' :]fYVcl ' DUbY'g'z' 7YfUa]W@c[g/ ' DUbY'g'z' 6i fbYfz' 7YfUa]W; ' Uggz' DYXYgh'U'g'z' DUbY'g' UbX' @Y[g' D'YUgY' gY' h\Y' Yl W' g]cbg' UbX']a]h]cb' gYV]cb' VY'ck' ' Ug' W'fU]b' fYgfr]M]cbg' UbX' Yl W' g]cbg' Udd'm' hc' h]g' k UffUbhm'

Limited Two (2) Year Warranty:

I bXYf' h]g' k UffUbhm' G\Yfk ccX' =bXi gfr]Yg' @X'' Vtj Yfg' ; Ug' 5ggYa V' n'z' 6'ck Yfz' 6'ck Yf' Vt' b'f'c' z' HYa dYfUhi fY' GYbgc]f]g' UbX' K]fY' < UfbYgg' U[U]bghi XYZVltg']b' a UHf]Ug' UbX' k cf_a Ubg\]d'z' Zcf' dUfh' fYdU]f' cf' fYd'UW'a Ybh' Zcf' h\Y' Ufgh' k c' f&k' n\Y'Ufg' hc' h\Y' cf]]]bU' di f\W'UgYf' D'YUgY' gY' h\Y' Yl W' g]cbg' UbX']a]h]cb' gYV]cb' VY'ck' ' Ug' W'fU]b' fYgfr]M]cbg' UbX' Yl W' g]cbg' Udd'm'hc' h]g' k UffUbhm'

Limited One (1) Year Warranty:

I bXYf' h]g' k UffUbhm' G\Yfk ccX' =bXi gfr]Yg' @X'' Vtj Yfg' U' Yl Hf]cf' g' fZUW' Ub]g\ Yg' U[U]bghi XYZVltg']b' a UHf]Ug' UbX' k cf_a Ubg\]d'z' Zcf' dUfh' fYdU]f' cf' fYd'UW'a Ybh' UbX']a]h\X' U'Vci f' Zcf' h\Y' Ufgh' f&k' n\Y'Uf' hc' h\Y' cf]]]bU' di f\W'UgYf' D'YUgY' gY' h\Y' Yl W' g]cbg' UbX']a]h]cb' gYV]cb' VY'ck' ' Ug' W'fU]b' fYgfr]M]cbg' UbX' Yl W' g]cbg' Udd'm'hc' h]g' k UffUbhm'

< YfY']g' \ck' 'ci f' K UffUbhm'k cf_g
=Z' nci ' \Uj Y' Ubm' Vt' b' W' f' b' g' k]h' nci f' 9bj]fc' dfcXi Vt'z' d'YUgY' Vt' b' h' U' m' h\Y' XYU'Yf' k \YfY' nci ' di f\W'UgYX' h\Y' UfYd'UW' cf' g'c] Y' M'ci f' XYU'Yf' g' U' a U_Y U' WU]a gi bXYf' h]g' k UffUbhm']b' k f]h]b["

To the Dealer

K \Yb' U']b[' ci hU' k UffUbhm' WU]a z' d'YUgY' Vt' a d'YH' h\Y' Z' ck']b[']b' Zcfa U]cb' cb' Ub' cZU]U' k UffUbhm' WU]a ' Zcfa . '

7i g'ca Yf']b' Zcfa U]cb. ' BUa Yz' UXXfYgg' UbX' h' Yd' cbY' bi a VYf' cZ di f\W'UgYf' UbX' XU' h' cZ di f\W'UgY' 8YU'Yf']b' Zcfa U]cb. ' 8U' h' cZ]bg' U' U]cb' z' bUa Y' cZ]bg' U' Yf' UbX' XYU'Yfz' gYf]U' bi a VYf' cZ h\Y' Udd']UbW'z' bUhi fY' cZ Vt' a d' U]b' z' XYZVltg' cf' a UZ' bV]cb' z' XYgV]d]h'cb' UbX' dUfh' bi a VYfg' cZ UbmdUfh' g' fYd' UWX' "

To the Distributor

G]] b' UbX' j Yf]z' m' h' U' h' k cf_ ' UbX']b' Zcfa U]cb' UfY' Vt' f' Y' Vt'

Exclusions and Limitations:

%' h]g' K UffUbhm' XcYg' bch' Vtj Yf' h' Uf]b]g\ z' X]g' Vt' cf' U]cb' cf' k YUf' cb' h\Y' d' U]b[' cf' dU]b' h' ' &' h]g' K UffUbhm' Yl W' XYg' k YUf' UbX' h' Uf' cf' VYfU' U[Y' WU] gYX' Vm' W' U]b[]z' a c]]b[' cf' gYfj]W' cb' ' c[' gYhi UbX' d' UbY' g' ' ' 5' ei U']YX']bg' U' Yf' a i gh']bg' U' h]g' g'c] Y' cf' UfYd'UW' " h]g' @]a]h\X' K UffUbhm' Vtj Yfg' XYZVltg']b' a UHf]Ug' UbX' k cf_a Ubg\]d' cb' m']Z' h\Y' dfcXi Vt' \ Ug' VYYb']bg' U' YX']b' U' W' V' f' X' UbW' k]h' ' c' W' Vi]X]b[' UbX' UfY' Vt' XYg' /]b' h\Y' f' U' W' gYbW' z' fYz' f' hc' h\Y' ck' bYf]g' a Ubi U' " =Z' h\Y' dfcXi Vt']g' XUa U[YX' cf' Vfc' Yb' Ug' U' fYg' ' h' cZ' Ubm' U' h' Y' U]cb' z' k]z' ' U' m' gYz' a]g' UbX']b[]z' U' W' X' Y' b' z' bY[' Y' Vt' z' cf' a]g' gY' cZ' h\Y' dfcXi Vt' z' h\Y' @]a]h\X' K UffUbhm' XcYg' bch' Udd' n'

K U f f U b h m

(" H\Y' grcj Y'a i gh'VY' cdYfUH\X' UbX' a U]bH]bYX' Uh'U''h]a Yg']b' UWz'fXUbW' k]h' h\Y']bgrfi V]cbg']b' h\Y' Ck bYf] A Ubi U'' =Z h\Y' i b]h' g\ck g'g] [bg' cZ bY ['VM' cf' a]g' gYz']h']g' bch Vtj YfYX' i bXYf' h\Y' h'fa g' cZ h']g' K UffUbm]dc']M' DYfZcfa UbW' d'fcV'Ya g' Xi Y' hc' cdYfU'cf' Y'f'cf' k]' bch'VY' Vtj YfYX' Vmi h\Y' @]a]h\X' K UffUbm]dc']M'

) " 5g h\]g']g' U' \YU]b [' Udd']UbWz' gca Y' V\Ub [Yg']b' Vt' ci f' cZ gi fZUW' Ub]g' \Yg' a UmcVW' f' h\]g']g' bch U' Uuk' UbX' Ug' gi V\]g' bch Vtj YfYX' i bXYf' h\]g' k UffUbm'

* " Gca Y' a]bcf' Yl dUbg]cbz' Vt' b'fUM]cbz' cf' a cj Ya Ybh' cZ W'fU]b' dUfhg' UbX' fYgi']h]b ['bc]gYz']g' b'cfa U' UbX' bch U' XYZV' M' UbXz' h\ YfYz' c'fYz']g' b'ch Vtj YfYX' i bXYf' h\]g' @]a]h\X' K UffUbm'

+ " A]g' gY']bW' XYg' cj Yf' U'f]b [' Cj Yf' U'f]b [' h\]g' Udd']UbW' V\Ub' V\U' gY' gYf' ci g' XUa U [Y' UbX' k]' bi ']Zmi h\Y' @]a]h\X' K UffUbm'

, " H\Y' @]a]h\X' K UffUbm]k]' Vtj Yf [' Ugg' h\ Yfa U' V'fYU' U [Y' cb' m'UbX' k]' bch Vtj Yf' a]g' gY' cZ h\Y' grcj Y' [' Uggz']bW' X]b [' Vi h' bch']a]h\X' hc' [' Ugg' h\ Uh']g' g'f'f' V\z' \Ug' gi fZUW' Vt' b'Ua]bU' h'g' cf' \Ug' \UX' \Ufg' \cf' U'fUg]j Y' V\Ub' Yfg' i gYX' cb']h'

- " H\]g' k UffUbm] XcYg' bch Vtj Yf' d'fcXi Vtj' a UX' ' cf' d'fcj]XYX' Vmi ch\Yf' a Ubi ZUM' fYfg' UbX' i gYX']b' Vt' b'f' b'V]cb' k]h' h\Y' cdYfU]cb' cZ h\]g' grcj Y' k]h' ci h' d'f'cf' U' i h' cf']h' U]cb' Z'ca' G\Yfk ccX' =bXi g'f']Yg' @X' " H\Y' i gY' cZ gi V\ d'fcXi Vtj' a Umi ']Zmi h\Y' @]a]h\X' K UffUbm]cb' h\]g' grcj Y' " =Z i bg' fY' Ug' hc' h\Y' Yl h' b'hcZ h\]g' @]a]h\X' K UffUbm] Vt' b'U' M' n'ci f' U' i h' cf']h\X' '9bj]f'c' XYU' Yf' VYz' c'fY']b'g' U' U]h'cb' "

%" " G\Yfk ccX' =bXi g'f']Yg' @X' " k]' bch'VY' fYg' d'cbg] VY' Z'cf']b'UX' Yei U' h' d'YfZcfa UbW' V\U' gYX' Vmi Ybj]f'c'ba Yb'U' Vt' b'X]h'cbg' "

%%" " H\Y' @]a]h\X' K UffUbm] XcYg' bch Vtj Yf']b'g' U' U]h'cb' UbX' cdYfU]cb' U' fY' U' h\X' d'fcV'Ya g' gi V\ Ug' i gY' cZ Xck bX' fUz' g' cf' gd'] U [Y' V\U' gYX' Vmi Ybj]f'c'ba Yb'U' Vt' b'X]h'cbg' " 9bj]f'c'ba Yb'U' Vt' b'X]h'cbg']b'W' XY' Vi h' U'fY' bch']a]h\X' hc' bYU'f' m' h' fY' Yg'z' Vi]X]b [g'z' f'ccZ h'cdg'z' k]b'Xz' \]' g'z' a ci b'U]b'g'z']b'UX' Yei U' h' j Yb]b [' cf' j Yb]h' U]h'cbz' Yl W'gg]j Y' cZ g'Yh'g'z' bY [U]h' Y' U]f' d'fYgg' fYg' cf' ch\ Yf']b'U' Yb'W'g' V\U' gYX' Vmi a V\U' b]U]V' g'g' h' Ya g' gi V\ Ug' Z' f' b'U' W'g'z' Z'Ub'g'z' Vt' h\ Yg' X'f' n'fYg' Y' h' W'

%&" " H\Y' @]a]h\X' K UffUbm]g' j c]X']Z' U' h' H\Y' grcj Y' \Ug' VY' Yb' cdYfU' h\X']b' U' ha cgd' \YfYg' Vt' b'Ua]b'U' h\X' Vmi V\ cf']b'Yz' U' i cf']b'Y' cf' ch\ Yf' XUa U []b [' V\Y' a]W'g' "

' Vt' H\Y' grcj Y']g' gi V'Y' M' h'c' gi Va Yfg]cb']b' k U' h'f' cf' d'fc' cb [YX' d'Yf' cXg' cZ XUa dbYgg' cf' Vt' b'XYbg' U]h'cb' "

' Vt' 5bm' XUa U [Y' hc' h\Y' i b]h'z' Vt' a Vi g' h'cb' V\Ua VYf' cf' ch\ Yf' Vt' a dcb' Yb'g' Xi Y' hc' k U' h'f'z' cf' k YU' h' Yf' XUa U [Y' k \]W']g' h\Y' fYgi' h'cZ' Vi h' bch']a]h\X' hc'z']a d'fcd' Yf' V\]a b'Ym'] Yb]b [']b'g' U' U]h'cb' "

' Vt' GU' h' U]f']b' Vt' U'g' U' U'fYUg' cf' \] [\ \ i a]X]m' V\Ub' VY' Vt' f'fcg]j Y' hc' h\Y' Ub]g' \ h\Y' gY' Ybj]f'c'ba Yb'g' V\Ub' V\U' gY' fi g' h]b [" 8Ua U [Y' V\U' gYX' Vmg' U' h' U]f' cf' \] [\ \ i a]X]m']g' bch' Vtj YfYX' Vmi h\Y' @]a]h\X' K UffUbm'

% " 9l W' g]cbg' hc' h\Y' @]a]h\X' K UffUbm]]b'W' XY']b' f' r'z' cgg' cZ i gYz' XUa U [Yz' ZU]i fY' hc' Z' b'V]cb' Xi Y' hc' U' W' X' Y' b' h'z' bY [] [Yb' W'z' a]g' gYz']a d'fcd' Yf']b'g' U' U]h'cbz' U' h'f' U]h'cb' cf' UX' g'ra Ybh' cZ h\Y' a Ubi ZUM' fYf'g' gY' h]b [g' cZ Vt' a dcb' Yb'g'z' U' W' cZ d'fcd' Yf' UbX' fY [i ' U'f' a U]b' h' b'Ub' W'z' U' h'f' U]h'cbz' cf' U' M' cZ; cX' "

%(" H\Y' @]a]h\X' K UffUbm] XcYg' bch Vtj Yf' XUa U [Y' V\U' gYX' hc' h\Y' U'fYd' U' W' cf' grcj Y' k \]Y']b' h'f' Ubg]h' " =Z h\]g' cVW' f'g'z' Xc' bch' cdYfU' h' h\Y' grcj Y' UbX' Vt' b'U' M' n'ci f' Vt' i fYf' UbX' #cf' XYU' Yf' "

%)" " @]a]h\X' K UffUbm] XcYg' bch Yl h' b'X' hc' cf']b'W' XY' U'fYVcl' d'U]b' h'z' Xccf' cf' [' Ugg' [Ug' Y' h'g' k]h' XUa U [Y' V\U' gYX' Vmi b'cfa U' k YUf' UbX' h'Y' U'f'z' cf' Yl h'f' cf' d'U]b' h' X]g' Vt' cf' U]h'cb' cf' V\]dd]b [z' k cfb [Ug' Y' h'g'z' Y' h' W'

%&" " H\Y' @]a]h\X' K UffUbm] XcYg' bch]b'W' XY' XUa U [Y' hc' h\Y' i b]h' V\U' gYX' Vmi U' i gYz']a d'fcd' Yf']b'g' U' U]h'cbz' cf' a cX] U' W' h'cb' cZ h\Y' i b]h'

%+ " 8Ua U [Y' hc' d' U' h'X' gi fZUW'g' V\U' gYX' Vmi Ub [Yf' d'f]b' h'g'z' g' V' U' h' W' Yg'z' a Y' h'X']h' Y' a g'z' cf' ch\ Yf' Yl h'f' b'U' g' Vt' fYg' UbX' fYg' Xi Yg' Yz' h'cb' h\Y' d' U' h'X' gi fZUW'g' Z'ca' h\Y' i gY' cZ U'fUg]j Y' V\Ub' Yfg' cf' d'c']g' Yg']g' bch Vtj YfYX']b' h\]g' k UffUbm'

% " " H\Y' @]a]h\X' K UffUbm] XcYg' bch Vtj Yf' h' U'f]b]g' \z' X]g' Vt' cf' U]h'cb' cf' k YUf' cb' h\Y' d' U' h'X' gi fZUW'g'

K U f f U b h m

- % " H\Y dU]bhcb H\Y A YH U'6f]W_@bYf'a UmdYY" H\g]gXi Y hc H\Y YI HfYa Y V\bx]hcbgUdd]YX hc H\Y dU]bhi Xi f]b['bcfa U'i gU[Y"'=h]g' bchU'Uuk 'UbX']g' bchV\j YfYX' i bXYf' k UffUbmh
- &\$" G\Yfk ccX' =bXi gfr]Yg @X"']g ZFY' cZ]UV]]mZcf' UbmXUa U[Yg Vli gYX' VmiH\Y' UfYd'UW' cf' gncj Yz' Ug' k Y'' Ug]bV\bj Yb]YbW' YI dYbgYg' UbX' a UHf]Ug" H\Y @ja]H\X' K UffUbmXcYg' bch V\j Yf']bV\YbHU' cf' V\bgYei Ybh]U' XUa U[Yg'
- &% " H\Y @ja]H\X' K UffUbmXcYg' bch V\j Yf' Ubm' cgg' cf' XUa U[Y']bW' ffYX' VmiH\Y' i gY' cf' fYa cj U' cZ Ubm' V\ta dcbYbh' cf' UddUfUhi g' hc' cf' Zfca' ' H\Y' 9bj]fc' UfYd'UW' cf' gncj Y' k]h'ci h' H\Y' YI dYgg' k f]H\Yb' dYfa]gg]cb' cZ G\Yfk ccX' =bXi gfr]Yg @X"' UbX' VYUf]b[' U' G\Yfk ccX' =bXi gfr]Yg @X"' UY' cZ Uddfcj U"
- &&" 5bm g]UHYa Ybh' cf' fYdfYgYbHU]cb' cZ 9bj]fc' dfcXi V\jg' UbX' H\Y]f' dYfZfa UbW' V\ebHU]bYX']b' 9bj]fc' UXj Yfh]g]b[' z' dUW]U[]b[']H\YfUhi fYz' cf' df]bH\X' a UHf]U']g' bchdUfhcZ H\Y @ja]H\X' K UffUbmh
- &' " H\Y @ja]H\X' K UffUbm]g' U' hca UH]W' m]j c]XYX']Z H\Y' UfYd'UW' cf' gncj Y]g' gYf]U' bi a VYf' \Ug' VYyb' fYa cj YX' cf' UHfYX']b' Ubmik Um' =Z H\Y' gncj Y']g' i gYX' Zcf' V\ta a YfV]U' di fdcgYg']h]g' YI W' XYX' Zfca' H\Y' @ja]H\X' K UffUbmh
- &(" Bc' XYUYfz X]gfr]Vi hc'z' cf' g]a]Uf' dYfgcb' \Ug' H\Y' U' h'cf]m]hc' fYdfYgYbh' cf' k UffUbh' 9bj]fc' dfcXi V\jg' VYncbX' H\Y' HfYa g' V\ebHU]bYX' k]h]b' H\Y' @ja]H\X' K UffUbmh' G\Yfk ccX' =bXi gfr]Yg @X"' Uggj a Yg' bc']UV]]mZcf' gi W' k UffUbh]Yg' cf' fYdfYgYbHU]cbg'
- &)" G\Yfk ccX' =bXi gfr]Yg @X"' k]' bchV\j Yf' H\Y' V\gncZ H\Y' fYa cj U' cf' fY!]bghU' U]h'cb' cZ H\Y' gncj Yz' \YUfh' z' ZUM]b[' z' a Ubh' g'z'] Ybh]b[' cf' ch\Yf' V\ta dcbYb]g'
- &* " @Uci f' hc' fYd'UW' cf' fYdU]f']HYa gi bXYf' H\g @ja]H\X' K UffUbm]k]' VY' V\j YfYX' dYf' ci f' k UffUbm]gYfj]W' ZY' fY]a Vi fgYa Ybhg\XYXi ' Y' @Uci f' fUH'g' UY' gYhdYf' V\ta dcbYbh' UbX' Ug' gi W' hc' HU' \Uci f' V\gng' a Um' bchVY' V\j YfYX'
- &+" G\Yfk ccX' =bXi gfr]Yg @X"']g' bch']UV' Y' Zcf' ZY][\h' cf' U'Vci f' cb' Ubm]gncj Y' fYd'UWX']b[UY' X' UbX']g' bch']UV' Y' Zcf' fUj Y' V\gng' Zcf' gYfj]W' k cf' _" =b' H\Y' Yj Ybh' cZ]b[\ca Y' fYdU]f' k cf' z' H\Y' W' gnc' a Yf' k]' dUm' Ubm']b[\ca Y' fUj Y' ZYg' cf' gYfj]W' W' Uf[Yg' fYei]fYX' VmiH\Y' 5i H'cf]H\X' 8YUYf'
- &' " 5h'bc' h]a Y' k]' G\Yfk ccX' =bXi gfr]Yg @X"' VY']UV' Y' Zcf' Ubm' V\bgYei Ybh]U' XUa U[Yg' k \]W' YI WYX' H\Y' di fW' UgY' df]W' cZ H\Y' i b]h' G\Yfk ccX' =bXi gfr]Yg @X"' \Ug' bc' cV][U]h'cb' hc' Yb\UbW' cf' a cX]Zm' Ubm' gncj Y' cbW' a Ubi ZUM] fYX' fYI Ua d'Y' Ug' U' gncj Y' Yj c] Yg'z' UY' X' a cX]UW]h'cbg' cf' i d[fUXYg' k]' bchVY' dYfZfa YX'z'
- &- " H\g @ja]H\X' K UffUbm]g' Udd']WV' Y' cb' m]hc' H\Y' cf][]bU' di fW' UgYf' UbX']h]g' bcb' fUbgZYfU' Y' "
- ' \$" H\g]k UffUbm]cb' m]V\j Yfg' 9bj]fc' dfcXi V\jg' H\U' HfY' di fW' UgYX' h' fci [\ Ub' U' h'cf]H\X' 9bj]fc' XYUYf'
- ' %" =Z' Zcf' Ubm]fUgcb' Ubm]g' V\h'cb' cZ H\Y' @ja]H\X' K UffUbm]g' XYWUfYX']bj U']Xz' H\Y' VU' UbW' cZ H\Y' k UffUbm' fYa U]bg']b' YZYV\h' UbX' U' ch\Yf' WU' gYg' g\U' fYa U]b']b' YZYV\h'
- ' &" H\Y @ja]H\X' K UffUbm]g' H\Y' cb' m]k UffUbm]gi dd']YX' VmiG\Yfk ccX' =bXi gfr]Yg @X"' z' H\Y' a Ubi ZUM] fYf' cZ H\Y' gncj Y' " 5" ch\Yf' k UffUbh]Yg'z' k \Yh' Yf' YI dYgg' cf']a d']YXz' UfY' \YfYVmiYI dYgg' m]X]gW]a YX' UbX' di fW' UgYf]g' fYV\z' fgY']g' YI dYgg' m]]a]H\X' hc' H\Y' @ja]H\X' K UffUbmh
- ' ' " G\Yfk ccX' =bXi gfr]Yg @X"' UbX']hg' Ya d' cmYg' cf' fYdfYgYbHU]h] Yg' k]' bch' Uggj a Y' Ubm' XUa U[Yg'z' Y]h' Yf' X]fYV\h' m]cf']bX]fYV\h' z' WU' gYX' Vm]a dfcdYf' i gU[Yz' cdYfU]h'cbz']bghU' U]h'cbz' gYfj]W]b[' cf' a U]bh' Yb' UbW' cZ H\g]gncj Y'
- ' (" G\Yfk ccX' =bXi gfr]Yg @X"' fYgYfj Yg' H\Y' f][\h' hc' a U_Y' W' Ub[Yg' k]h'ci h' bch]W' " D'YUg' V\ta d' YH' UbX' a U] ' H\Y' k UffUbm]fY[]gfr]U]h'cb' W' fX' UbX' \Uj Y' H\Y']bghU' Yf' U']b' H\Y']bghU' U]h'cb' XU' H' g\Y' Yh]b' H\Y' VUW' cZ H\Y' a Ubi U' Zcf' k UffUbm]UbX' z' h' fY' fYZfYbW'
- ') " G\Yfk ccX' =bXi gfr]Yg @X"']g' fYgdcbg]V' Y' Zcf' gncW]b[' dUf]g' Zcf' U' a U]]a i a' cZ gYj Yb' f]h' n' YUfg' UZHYf' X]gV\eb]bi]b[' H\Y' a Ubi ZUM] fY' cf']bV\fdcfU]h'cb' cZ H\Y']HYa']bhc']hg' dfcXi V\jg' " 5b' YI Wdh]cb' hc' H\g] k ci ' X' VY']ZUb' C9A' gi dd']Yf']g' bch' UV' Y' hc' gi dd' m' U' dUfh'

